

FADINI
l'apricancello
Made in Italy

I

LIBRETTO DI ISTRUZIONI
Elpro • 70/3 PLUS

MONOFASE - TRIFASE
PER SCORREVOLE MEC 200

- FUNZIONE PASSO PASSO
- APERTURA PEDONALE
- UOMO PRESENTE
- SPIA DI SEGNALAZIONE DELLO STATO DELL'AUTOMAZIONE
- LUCE DI CORTESIA TEMPORIZZATA

pag. 2,3,4

GB

INSTRUCTIONS
Elpro • 70/3 PLUS

SINGLE-/THREE-PHASE
FOR SLIDING GATE OPERATORS MEC 200

- STEP BY STEP
- PEDESTRIAN OPENING
- HOLD-ON SWITCHED (DEADMAN) CONTROL
- GATE STATUS INDICATION
- ADJUSTABLE COURTESY LIGHT TIME

page 5,6,7

F

NOTICES D'INSTRUCTION
Elpro • 70/3 PLUS

MONOPHASE - TRIPHASE
POUR PORTAILS COULISSANTS MEC 200

- FONCTION PAS PAS
- OUVERTURE PIETONS
- FONCTION HOMME MORT
- SIGNALISATION DE L'ETAT DE L'AUTOMATISME PAR VOYANT
- LAMPE TEMOIN TEMPORISEE

page 8,9,10

D

ANLEITUNG
Elpro • 70/3 PLUS

EINPHASIG - DREIPHASIG
FÜR SCHIEBETORANTRIEB MEC 200

- SCHRITT-IMPULS-FUNKTION
- TOTMANN-BEDIENUNG
- GEHÜRFUNKTION
- AUTOMATION-ZUSTAND ANZEIGELAMPE
- EINSTELLBARE DECKENLEUCHTEZEIT

Seite 11,12,13

E

FOLLETO DE INSTRUCCIONES
Elpro • 70/3 PLUS

MONOFASICO - TRIFASICO
PARA VERJAS DESLIZANTES MEC 200

- FUNCIONAMIENTO PASO A PASO
- ABERTURA PARA PASO DE PEATONES
- HOMBRE PRESENTE
- LÁMPARA TESTIGO QUE SEÑALA EL ESTADO DEL AUTOMATISMO
- LUZ AUXILIAR TEMPORIZADA

pág. 14,15,16

NL

HANDLEIDING
Elpro • 70/3 PLUS

EENFASE-DRIEFASE
VOOR SCHUIFHEKOPENER MEC 200

- STAP-VOOR-STAP FUNCTIE
- VOETGANGERSDOORGANG
- DODEMANSFUNCTIE
- SIGNALERINGSGLAMP AUTOMATISERINGSSTATUS
- INSTELBARE INDICATIELAMP

pag. 17,18,19

Dis. N. 4138



Via Mantova, 177/A - 37053 Cerea (Verona) Italy - Tel. +39 0442 330422 r.a.
Fax +39 0442 331054 - e-mail: info@fadini.net - www.fadini.net





FADINI
l'apricancello
Made in Italy

I Elpro 70/3 PLUS

MONOFASE - TRIFASE PER SCORREVOLE MEC 200

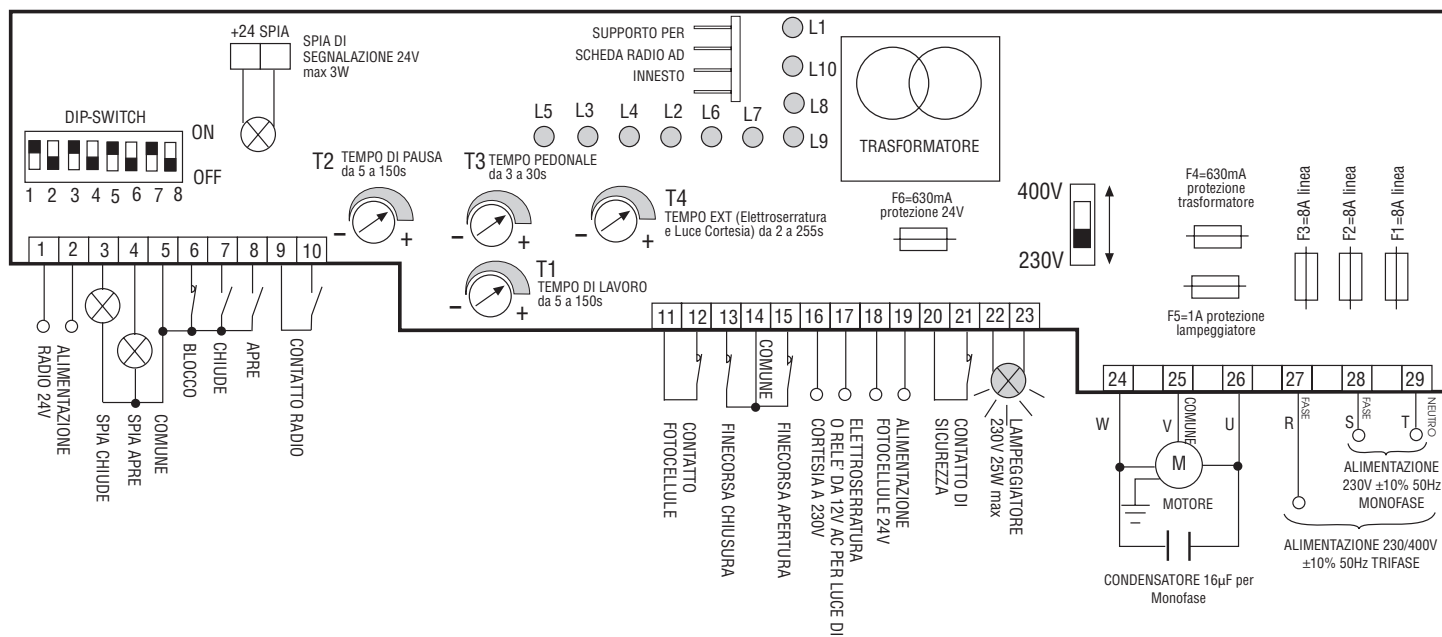

Descrizione generale: Il programmatore Elpro 70/3 Plus di nuova generazione, è utilizzato negli apricancelli scorrevoli MEC 200. Alimentato a 230V-400V monofase e trifase, risponde alle normative di sicurezza di Bassa Tensione 2006/95/CE e Compatibilità Elettromagnetica 2004/108/CEE e 92/31/CEE, e pertanto si consiglia l'installazione da parte di personale tecnico qualificato secondo le normative di sicurezza vigenti. La Ditta costruttrice non si assume responsabilità circa l'uso improprio del programmatore; inoltre si riserva di apportare modifiche e aggiornamenti al presente libretto e al programmatore. **L'inosservanza delle regole di installazione può provocare seri danni a cose e persone.**



IMPORTANTE:

- Il programmatore è installato all'interno dell'automazione MEC 200.
 - Accertarsi che l'alimentazione al programmatore elettronico sia 230V ±10% oppure 400V ±10%.
 - Accertarsi che l'alimentazione al Motore Elettrico sia 230V ±10% oppure 400V ±10%.
 - Per distanze superiori ai 50 metri aumentare la sezione dei fili.
 - Applicare un Interruttore Magneto-Termico differenziale del tipo 0,03A ad alta sensibilità all'alimentazione del programmatore.
 - Alimentazione, Motore elettrico, Lampeggiante usare cavi con fili da 1,5 mm² fino a 50m di distanza; per Finecorsa e accessori vari utilizzare cavi con fili da 1mm².
 - Se non si usano le Fotocellule eseguire un ponte tra i morsetti 11 e 12.
 - Se non si usa nessuna Pulsantiera eseguire un ponte tra i morsetti 5 e 6.
- N.B:** Per applicazioni quali accensione luci, telecamere, ecc. utilizzare Relè Statici per non creare disturbi al microprocessore.

Dip-Switch:

- 1= ON Fotocellula ferma in apertura
- 2= ON Radio non inverte in apertura
- 3= ON Chiude in Automatico
- 4= ON Prelampeggio Attivo
- 5= ON Radio passo-passo con blocco intermedio
- 6= ON Servizio a uomo presente (Dip 4=OFF e Dip 3=OFF)
- 7= ON Lampeggiatore spento durante la pausa in Automatico
- 8= OFF, libero

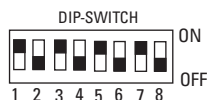

Nel caso di mancato funzionamento:

- Accertarsi che l'alimentazione al programmatore elettronico sia 230V ±10% oppure 400V ±10%
- Accertarsi che l'alimentazione al Motore Elettrico sia 230V ±10% oppure 400V ±10%
- Per distanze superiori ai 50 metri aumentare la sezione dei fili
- Controllare i fusibili
- Controllare che le Fotocellule siano in contatto chiuso
- Controllare tutti i contatti chiusi NC
- Controllare che non ci sia una caduta di tensione tra programmatore e motore elettrico

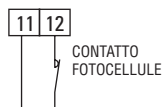
COLLEGAMENTI ELETTRICI IN BASSA TENSIONE
Fotocellule:

DIP-SWITCH 1:

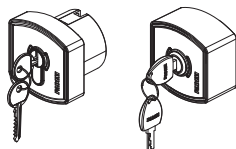
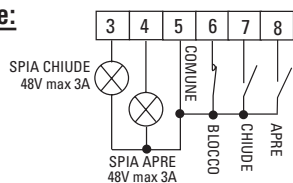
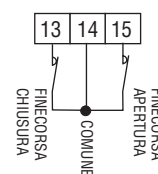
- ON: Fotocellula ferma in apertura e inverte in chiusura a ostacolo rimosso
 1 OFF: Fotocellula non ferma in apertura e inverte in chiusura in presenza di ostacolo

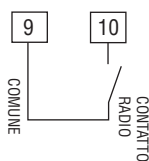

Selettore a chiave:

Finecorsa:

Contatto Radio:

- Apre/Chiude (normale)
- Inversione di marcia ad ogni impulso
- Passo Passo

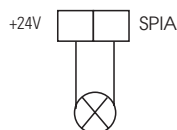
DIP-SWITCH 2 e 5 (NON devono mai essere contemporaneamente ON):

- ON: Non inverte in apertura
 2 OFF: Inverte la marcia ad ogni impulso

- ON: Passo passo con blocco intermedio
 5 OFF: Funzionamento normale

Spia 24V 3W di Segnalazione:

- Spia **Accesa** = Cancelli Aperto
 Spia **Spenta** = Cancelli Chiuso
 Lampeggia a **0,5s (veloce)** = movimento di chiusura
 Lampeggia a **1s (normale)** = movimento di apertura
 Lampeggia a **2s (lento)** = automazione in blocco

Alimentazione Radio:

Contatto di sicurezza:

Elettroserratura:

Regolare il Trimmer T4 al minimo, l'Elettroserratura rimane eccitata per 2 secondi

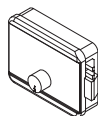
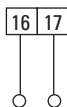
Luce di Cortesia:

Collegare un Relè modulare da 24VCA (Trimmer T4 da 2s a 255s) per far funzionare una lampada a 230V





FADINI
l'apricancello
Made in Italy

I Elpro-70/3 PLUS

MONOFASE - TRIFASE PER SCORREVOLE MEC 200

COLLEGAMENTI ELETTRICI DI POTENZA

Motore Monofase (230V) e Trifase (400V):

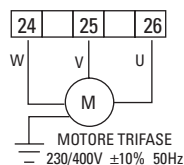
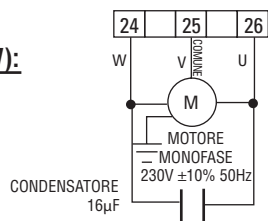

Lampeggiante:

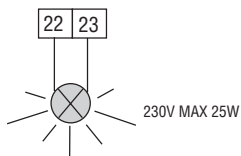

DIP-SWITCH 4 e 7:

ON: Prelampeggio
OFF: Senza prelampeggio
4

ON: Lampeggiatore Disattivato durante la pausa in automatico
OFF: Lampeggia durante la pausa in automatico
7

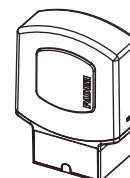

Alimentazione:

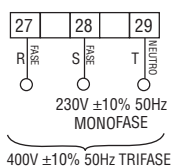

FUNZIONI

Automatico/ Semiautomatico:



DIP-SWITCH 3

ON: Chiude in Automatico
OFF: Non chiude in Automatico.
3

Apertura Pedonale:

Trimmer T3 da 3 a 30s Attivabile con un impulso di comando (anche radio), di durata superiore ai 2s

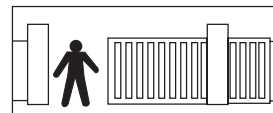
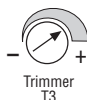

Uomo Presente:

DIP-SWITCH 6

ON= Uomo Presente con Dip-switch 4=OFF e Dip-switch 3=OFF
OFF= Funzionamento Normale
6

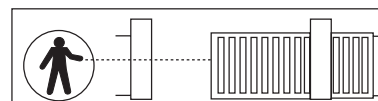

Led di Diagnostica:

- L1 = Alimentazione 230V 50Hz è acceso
- L2 = Fotocellule, si spegne ad ostacolo presente
- L3 = Apre, si illumina ad impulso del comando di apertura
- L4 = Chiude, si illumina ad impulso del comando di chiusura
- L5 = Blocco, si spegne ad impulso del comando di stop
- L6 = Radio, si illumina ad ogni impulso dal trasmettitore
- L7 = Stato dell'automazione, lampeggia durante il movimento
- L8 = Finecorsa chiude, spento a cancello chiuso
- L9 = Finecorsa apre, spento a cancello aperto
- L10 = Si accende per il tempo impostato dal Trimmer T4

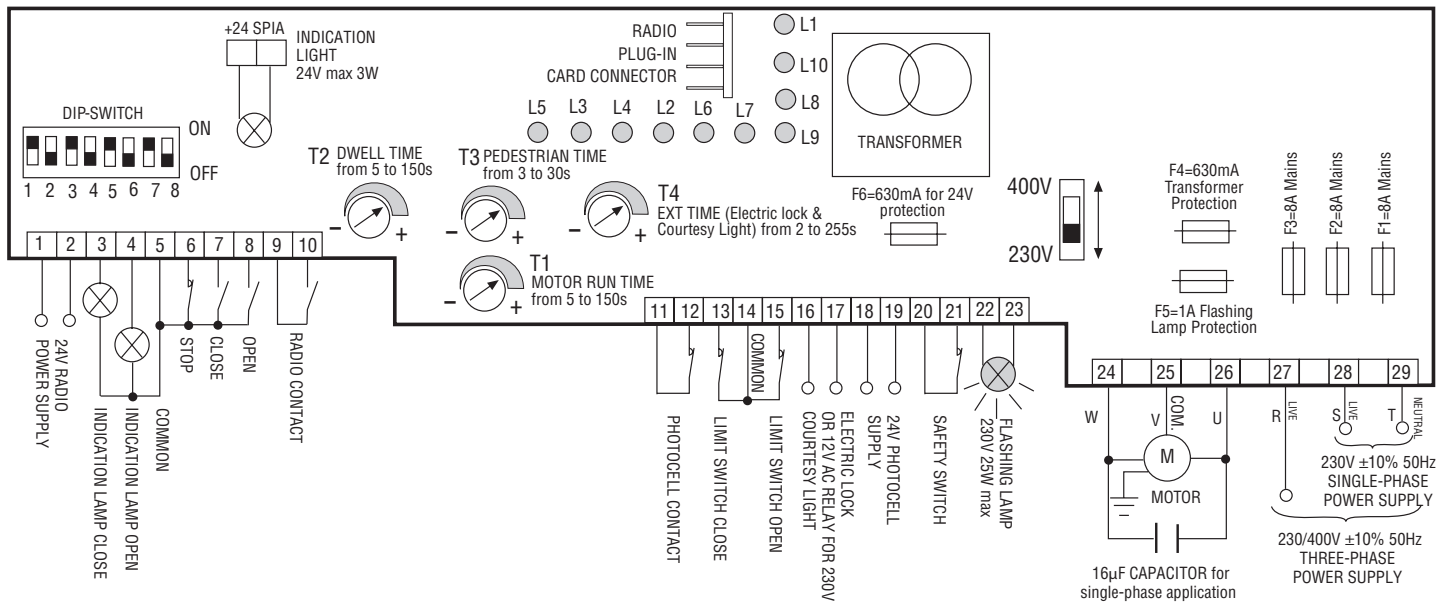

General description: The electronic control panel Elpro 70/3 Plus, new generation, is designed to operate the sliding gate operators MEC 200. Power supply is 230-400V single- and three-phase. It is built in full compliance with the Low Voltage 2006/95/CE and Electro-Magnetic Compatibility Regulations 2004/108/EEC - 92/31/EEC. Fitting operations are recommended to be carried out by a qualified technician in conformity to the existing safety standards. The manufacturing company declines any responsibility for incorrect handling and applications; also, it reserves the right to change or update the control panel any time. **Failure to follow the installation regulations may result in serious damages to properties and persons.**



PLEASE NOTE:

- The control panel is fitted inside Mec 200.
 - Make sure that the power supply to the electronic programmer is 230V ±10% or 400V ±10%.
 - Make sure that the power supply to the Electric Motor is 230V ±10% or 400V ±10%.
 - For distances of over 50 metres we recommend using electric cables with bigger sections.
 - Fit the mains to the control panel with a 0.03A high performance circuit breaker.
 - Use 1.5 mm² section wires for voltage supply, electric motor and flashing lamp. Maximum recommended distance 50 m. Use 1 mm² section wires for limit switches, photocells, push-buttons/key-switch and accessories.
 - Bridge terminals 11 and 12 if no photocells are required.
 - Bridge terminals 5 and 6 if no key- or push-button switches are required.
- N.W.:** To fit extra accessories such as lights, CCTV etc. use only solid state relays to prevent damages to the microprocessor.

Dip-Switch:

- 1= ON Photocells. Stop on opening
- 2= ON Radio. No reversing on opening
- 3= ON Automatic closing
- 4= ON Preflashing activated
- 5= ON Radio. Step by step, stop in between
- 6= ON Deadman Control (Dip 4=OFF n Dip 3=OFF)
- 7= ON No light during dwell time
- 8= OFF. Blank

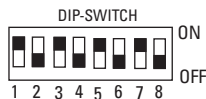

In case of failure of the panel:

- Make sure that the power supply to the electronic programmer is 230V ±10% or 400V ±10%
- Make sure that the power supply to the Electric Motor is 230V ±10% or 400 V ±10%
- For distances of over 50 metres we recommend using electric cables with bigger sections.
- Check fuses
- Check photocells if contacts are normally closed
- Check all NC contacts
- Check that no voltage drop has occurred from the control panel to the electric motor

LOW VOLTAGE ELECTRICAL CONNECTIONS

Photocell:

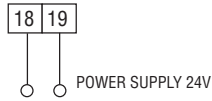
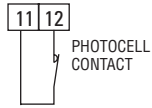

DIP-SWITCH 1:

- ON: Photocells stop gate while opening, reverse it on closing once obstacle is removed
- 1 OFF: Photocells do not stop gate while opening, reverse it on closing in case of an obstacle



Key-Switch:

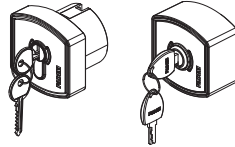
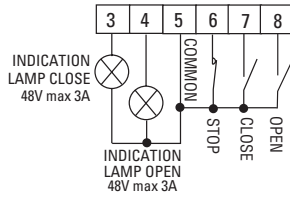

Limit switch:

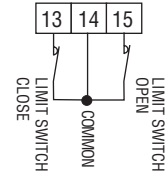

Radio Contact:

- Open/Close (Standard)
- Travel reversing on pulsing
- Step by step

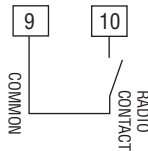

DIP-SWITCH 2 and 5 (NEVER set BOTH of them to ON at the same time):

- ON: Gate is not reversed while opening
- 2 OFF: Any pulse reverses the gate

- ON: Step by step. Stop in between
- 5 OFF: Standard operating mode

24V 3W Indication Light:

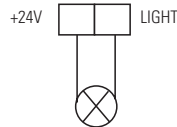

- Light **ON** = Open gate
- Light **OFF** = Closed gate
- Flashing (**fast**) **0.5s** = Closing gate
- Flashing (**normally**) **1s** = Opening gate
- Flashing (**slowly**) **2s** = gate is stopped

Radio Power Supply

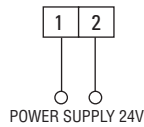

Safety Switch

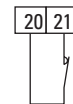

Electric lock:

Set the T4 Trimmer Time to the lowest value
The electric lock is excited for 2 seconds



Courtesy light:

Connect a 24VAC Modular Relay (T4 Trimmer Time from 2s to 255s) to operate a 230V lamp



ELECTRICAL POWER CONNECTIONS

Single- (230V) and Three-phase (400V) Motors:

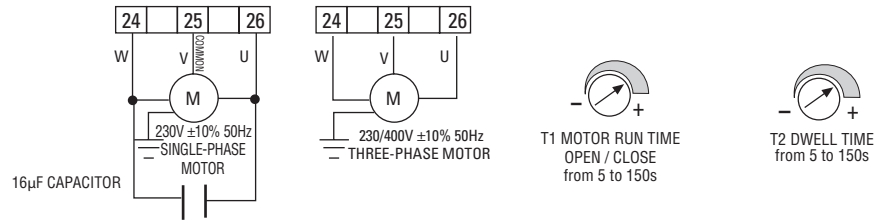

Flashing lamp:

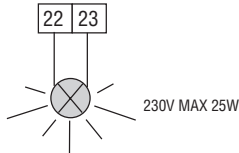

DIP-SWITCH 4 and 7:

ON: Pre-flashing
 OFF: No pre-flashing
4

ON: Lamp is not operating during Dwell Time. Automatic Mode.
 OFF: It flashes during Dwell Time. Automatic Mode.
7

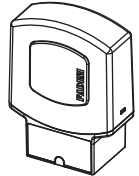

Power supply:

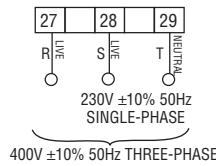

OPERATING MODES

Automatic / Semiautomatic:

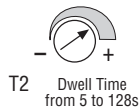

DIP-SWITCH 3

ON= Automatic Closing
 OFF= No Automatic. Semi-automatic closing by pulse
3

Pedestrian Opening:

Trimmer T3 from 3 to 30s.
It can be activated by any pulse (eg. by remote control) superior to 2s

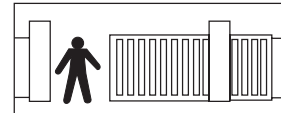

Hold on switched (Deadman) control:

DIP-SWITCH 6

ON= Deadman Control. Dip-switch 4=OFF and Dip-switch 3=OFF
 OFF= Standard Operations
6

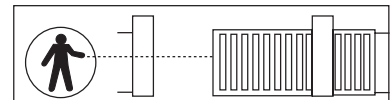

Led Status Indication:

- L1 = 230V 50Hz power supply. Alight
- L2 = Photocells, if obstructed light goes off
- L3 = Open. Alight whenever an Open pulse is given
- L4 = Close. Alight whenever a Close pulse is given
- L5 = Stop. It goes off on pulsing Stop
- L6 = Radio. It goes on by pressing a transmitter button
- L7 = Gate Status; it flashes on gate moving
- L8 = Limit switch Close; off when gate is closed
- L9 = Limit switch Open; off when gate is open
- L10= It stays on for a time equal to the time set on T4 Trimmer

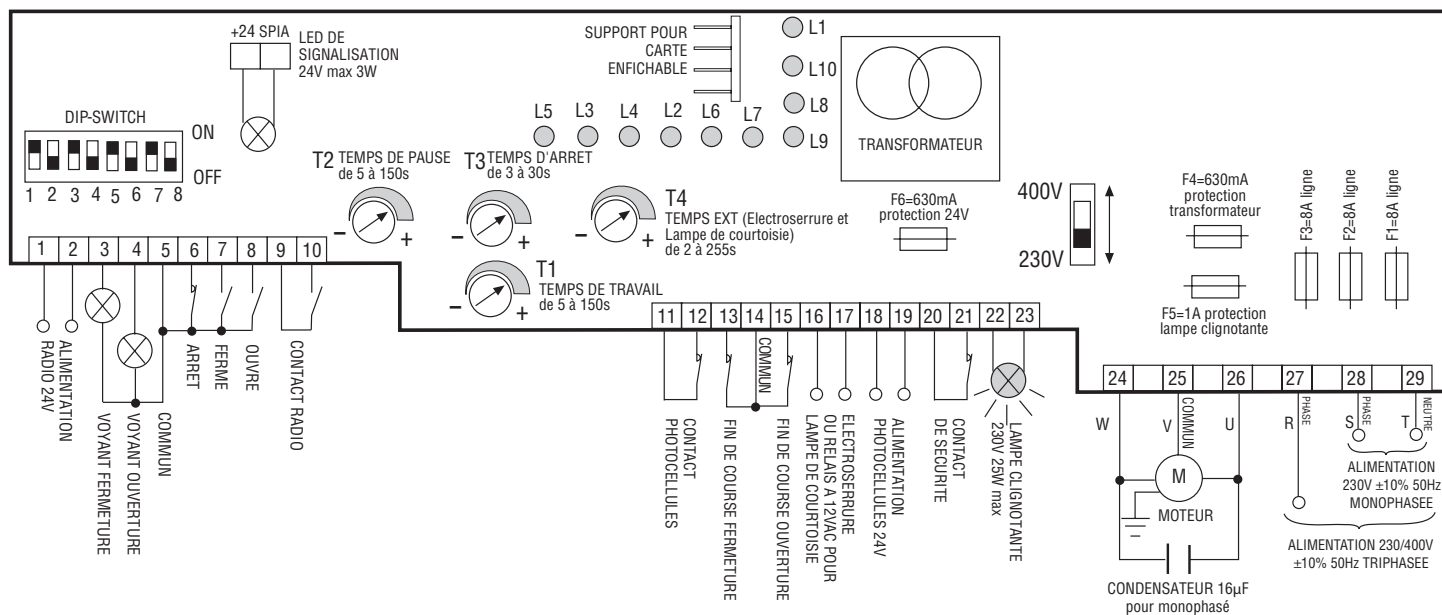

Description générale: Le programmeur Elpro 70/3 Plus de nouvelle conception est utilisé pour les opérateurs coulissants Mec 200. Alimenté en 230/400V monophasé et triphasé, il est en conformité aux normes de sécurité de Basse Tension 2006/95/CE et Compatibilité Electromagnétique 2004/108/CEE et 92/31/CEE. On en conseille l'installation par un technicien spécialisé, selon les normes de sécurité en vigueur. Le constructeur décline toute responsabilité pour l'utilisation impropre du programmeur et il se réserve le droit de modifier ou d'apporter des modifications au programmeur ou à cette notice à n'importe quel moment. **En ne respectant pas les règles de montage vous risquez de provoquer des lésions personnelles et des dégâts matériels importants.**



IMPORTANT:

- Le programmeur doit être installé à l'intérieur de l'automatisme MEC 200.
 - Assurez-vous que l'alimentation au programmeur électronique est de 230V ±10% ou 400V ±10%.
 - Assurez-vous que l'alimentation au Moteur Electrique est de 230V ±10% ou 400V ±10%.
 - Pour distances supérieures aux 50 mètres augmenter la section des fils.
 - Appliquez à l'alimentation du programmeur un interrupteur Magnéto-thermique différentiel du type 0,03A à haute sensibilité.
 - Pour Alimentation, Moteur électrique, Lampe de signalisation utilisez des câbles à fils de 1,5 mm² pour distances à 50 mt; pour Fin de course et accessoires il suffit 1 mm².
 - Si l'on n'utilise pas les photocellules, accouplez à pont les bornes 11 et 12.
 - Si l'on n'utilise aucun poussoir accouplez à pont les bornes 5 et 6.
- N.B: Pour applications telles que: allumage de lumières, caméra de télévision etc, utiliser Relais statiques pour éviter dérangements au microprocesseur

Dip-Switch:

- 1= ON Photocellule arrête à l'ouverture
- 2= ON Radio n'inverse pas en ouverture
- 3= ON Refermeture Automatique
- 4= ON Présignalisation
- 5= ON Pas-pas avec arrêt intermédiaire
- 6= ON Homme mort (Dip 4=OFF et Dip 3=OFF)
- 7= ON Lampe clignotante non-activée en pause en automatique
- 8= OFF, libre

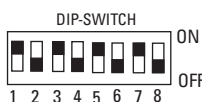

Au cas où le programmeur ne fonctionne pas:

- Assurez-vous que l'alimentation au programmeur électronique est de 230V ±10% ou 400V ±10%
- Assurez-vous que l'alimentation au Moteur Electrique est de 230V ±10% ou 400V ±10%
- Pour distances supérieures aux 50 mètres augmenter la section des fils.
- Contrôler les fusibles
- Contrôler que les photocellules soient en contact fermé
- Contrôler tous les contacts fermés NF
- Contrôler qu'il n'y ait pas de chute de tension entre le programmeur et le moteur électrique

RACCORDEMENTS ELECTRIQUES EN BASSE TENSION

Photocellules:

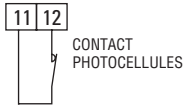

DIP-SWITCH 1:

- ON: Photocellule arrête en ouverture et inverse en fermeture après le dégagement de l'obstacle
- 1 OFF: Photocellule n'arrête pas à l'ouverture et inverse en fermeture en présence d'un obstacle

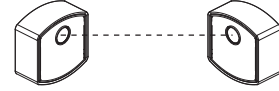

Sélecteurs à clé

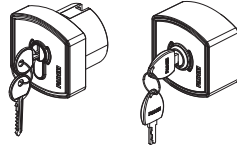
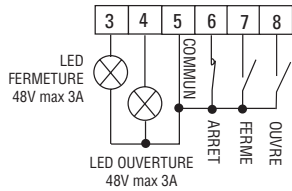

Fin de course:

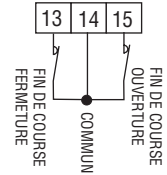

Contact Radio:

- Ouvre/Ferme (normal)
- Inversion du sens de marche à chaque impulsion
- Pas-pas

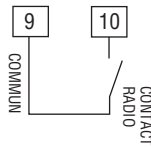

DIP-SWITCH 2 et 5 (NE doivent JAMAIS être en même temps sur ON):

- ON: N'inverse pas en ouverture
- 2 OFF: Inverse le sens de marche à chaque impulsion

- ON: Pas-pas avec arrêt intermédiaire
- 5 OFF: Fonctionnement normal

Voyant 24V 3W de Signalisation:

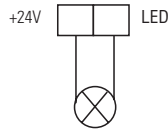

- Voyant **Allumé** = Portail Ouvert
- Voyant **Eteint** = Portail Fermé
- Clignote à **0,5s (rapide)** = mouvement de fermeture
- Clignote à **1s (normal)** = mouvement d'ouverture
- Clignote à **2s (lent)** = automatisme à l'arrêt

Alimentation Radio:

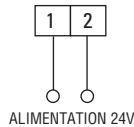

Contact de sécurité:



Electroserrure:

Réglez le Potentiomètre T4 au minimum, l'Electroserrure reste excitée pour 2s

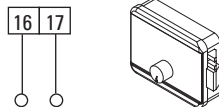

Lampe d'éclairage:

Raccorder un Relais modulaire de 24VCA (Potentiomètre T4 de 2s à 255s) pour allumer une lampe à 230V



RACCORDEMENTS ELECTRIQUES DE PUISSANCE

Moteur Monophasé (230V) et Triphasé (400V):

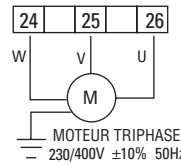
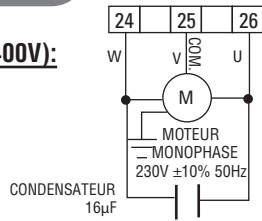

Lampe de signalisation:

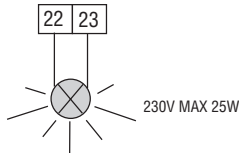

DIP-SWITCH 4 et 7:

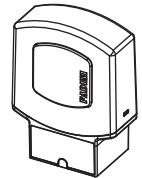
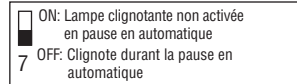

Alimentation:

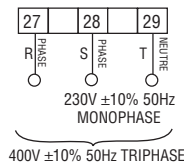

FONCTIONS

Automatique/Semiautomatique:



DIP-SWITCH 3

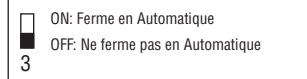

Ouverture Piéton:

Potentiomètre T3 de 3 à 30s Activée avec une impulsion de commande (même radio) de 2s

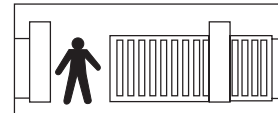

Fonction Homme Mort:

DIP-SWITCH 6

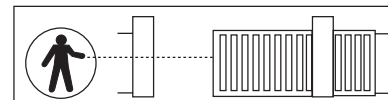

Led de Diagnostic:

- L1 = Alimentation 230V 50Hz allumée en présence de tension
- L2 = Photocellule s'éteint en cas d'obstacle
- L3 = Ouvre, s'allume à l'impulsion de commande d'ouverture
- L4 = Ferme, s'allume à l'impulsion de commande de fermeture
- L5 = Arrêt, s'éteint à l'impulsion de commande d'arrêt
- L6 = Radio, s'allume à chaque impulsion de l'émetteur
- L7 = Etat de l'automation, clignote durant le mouvement
- L8 = Fin de course en fermeture, éteint lorsque le portail est fermé
- L9 = Fin de course en ouverture, éteint lorsque le portail est ouvert
- L10 = S'allume pour le temps rentré dans le Potentiomètre T4

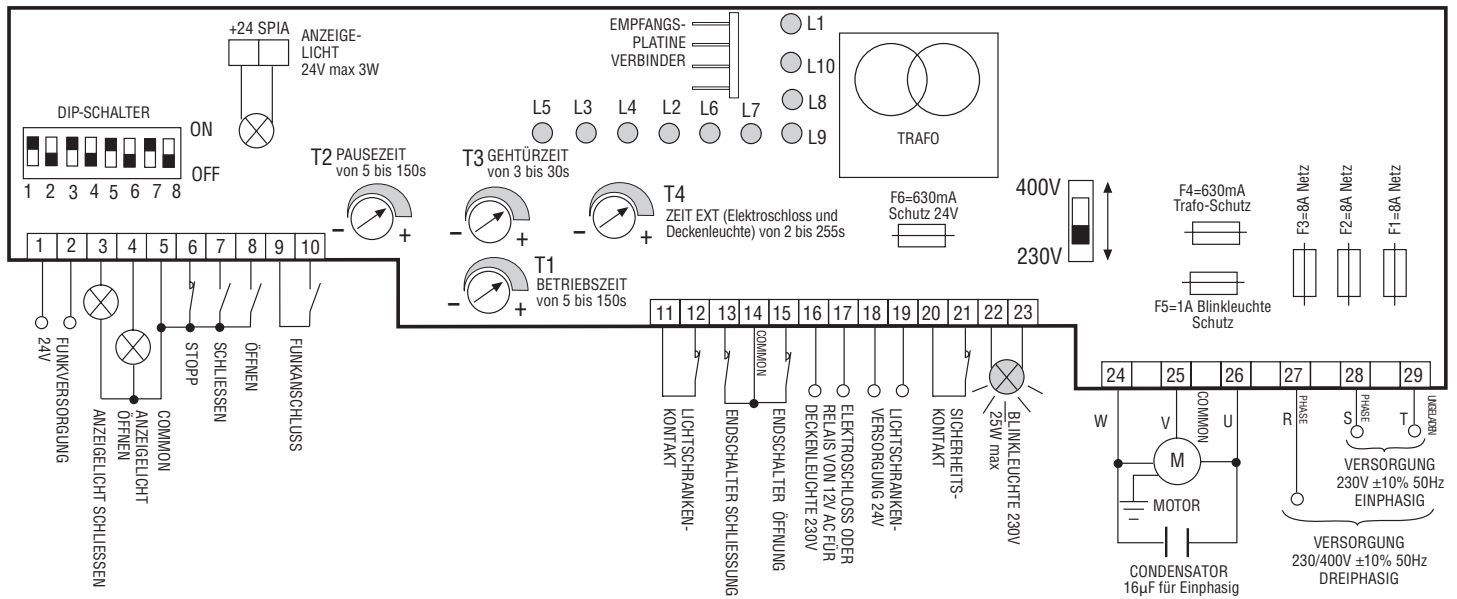

Allgemeine Beschreibung: Die Steuerung Elpro 70/3 Plus, neuer Konzeption, wird für die Schiebetorantriebe MEC 200 verwendet. Einphasige bzw. dreiphasige 230V/400V Versorgung, entspricht den Sicherheitsnormen, was Niederspannung 2006/95/EG und elektromagnetische Kompatibilität 2004/108/EWG - 92/31/EWG betrifft. Die Installation muss durch qualifizierte Fachleute gemäss den gültigen Vorschriften erfolgen. Die Herstellerfirma übernimmt keine Haftung für eine falsche Verwendung des Apparats und behält sich vor, Änderungen und Verbesserungen an der Steuerung vorzunehmen. **Die Nichteinhaltung der vorliegenden Sicherheits- und Installationsnormen kann schwere Sach- oder Personenschäden verursachen.**

ACHTUNG:

- Die Steuerung ist im Antrieb MEC 200 eingebaut.
 - Prüfen Sie die Versorgung an die elektronische Steuerung, sie muss $230V \pm 10\%$ oder $400V \pm 10\%$ sein.
 - Prüfen Sie die Versorgung an den E-Motor, sie muss $230V \pm 10\%$ oder $400V \pm 10\%$ sein.
 - Für Abstände über 50 Meter wird es empfohlen Kabel mit Drähten von höheren Querschnitten zu verwenden.
 - Der Steuerung einen hochempfindlichen magneto-thermischen Differenzialschalter Typ 0,03A vorschalten.
 - Für Versorgung, E-Motor und Blinkleuchte Kabel mit Drähten von $1,5 \text{ mm}^2$ Durchmesser bis zum Abstand von 50 m verwenden; für Endschalter und Zubehör Drähte von 1 mm^2 Durchmesser.
 - Werden keine Lichtschranken verwendet, müssen die Klemmen 11 u. 12 überbrückt werden.
 - Werden keine Drucktasten verwendet, müssen die Klemmen 5 u. 6 überbrückt werden
- NB:** Werden Zusätze wie Videokameras, Leuchten, etc. angeschlossen, müssen statische Relais verwendet werden, da ansonsten Störungen beim Mikroprozessor auftreten können.

Dip-Schalter:

- 1= ON Lichtschranke stoppt während der Öffnung
- 2= ON Funk. Keine Umkehr während der Öffnung
- 3= ON Automatisches Schliessen
- 4= ON Vorblinken aktiv
- 5= ON Funkkontakt. Schritt für Schritt. Mittelstopp
- 6= ON Totmannbedienung (Dip 4=OFF und Dip 3=OFF)
- 7= ON Ausgeschaltete Blinkleuchte während der Haltezeit
- 8= OFF Frei

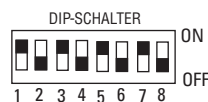
Fehlersuche bei Betriebsstörung der Steuerung

- Prüfen Sie die Versorgung an die elektronische Steuerung, sie muss $230V \pm 10\%$ oder $400V \pm 10\%$ sein.
- Prüfen Sie die Versorgung an den E-Motor, sie muss $230V \pm 10\%$ oder $400V \pm 10\%$ sein.
- Für Abstände über 50 Meter wird es empfohlen Kabel mit Drähten von höheren Querschnitten zu verwenden.
- Kontrollieren Sie die Sicherungen
- Kontrollieren Sie, ob die Lichtschranken einen NC Anschluss aufweisen
- Kontrollieren Sie alle NC Schliesskontakte
- Kontrollieren Sie, dass zwischen Steuerung und E-Motor kein Spannungsabfall vorliegt.

KLEINSPANNUNGSANSCHLÜSSE

Lichtschranken:

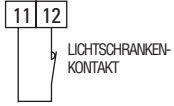

DIP-SCHALTER 1:

- ON: Lichtschranke stoppt während der Öffnung, kehrt bei Schliessung nach Entfernung des Hindernisses um
- 1 OFF: Lichtschranke stoppt nicht während der Öffnung. Kehrt während der Schliessung beim Hindernis um



Schlüsselschalter:

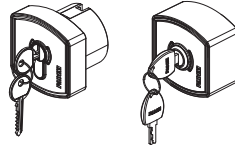
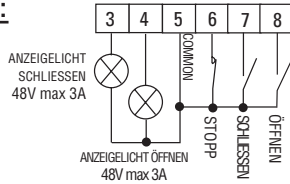

Endschalter:

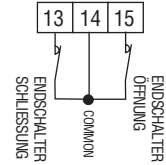

Funkkontakt:

- Öffnen/Schliessen (normal)
- Umkehr bei jeder Impulsgebung
- Schritt-Impuls-Funktion

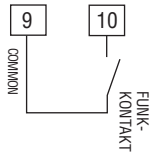

DIP-SCHALTER 2 und 5 (Sie müssen NIE gleichzeitig auf ON sein):

- ON: Keine Umkehr während der Öffnung
- 2 OFF: Umkehr bei jeder Impulsgebung

- ON: Schritt für Schritt mit Zwischenhalt
- 5 OFF: Normale Funktion

Anzeigelicht 24V 3W:

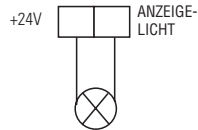

- Anzeigelicht **An** = offenes Tor
- Anzeigelicht **Aus** = geschlossenes Tor
- 0,5s** Blinken (**schnell**)= Schliessbewegung
- 1s** Blinken (**normal**)= Öffnungsbewegung
- 2s** Blinken (**langsam**)= blockierte Automation

Funk-Versorgung:



Sicherheitskontakt:



Elektroschloss

Das Trimmer T4 auf Minimum einstellen, das Elektroschloss bleibt 2 Sekunden erregt

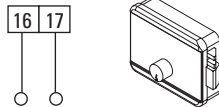

Deckenleuchte:

Ein 24VAC modulares Relais (Trimmer T4 von 2s bis 255s) anschalten, um eine 230V Lampe funktionieren lassen.

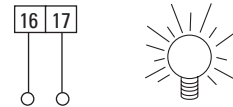



NETZSPANNUNGSANSCHLÜSSE

Einphasiger (230V) und dreiphasiger (400V) Motor:

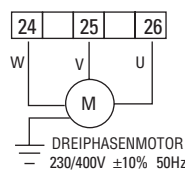
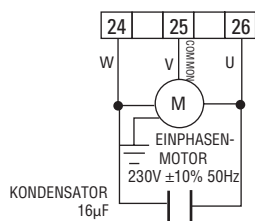

Blinkleuchte:

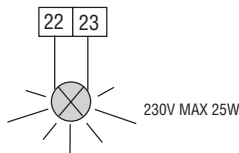

DIP-SCHALTER 4 und 7:

ON: Vorblinken
 OFF: Ohne Vorblinken
 4

ON: Blinkleuchte ist während der Haltezeit ausgeschaltet. Automatischer Betrieb
 7 OFF: Sie blinkt während der Haltezeit. Automatischer Betrieb

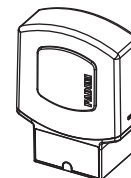

Versorgung:

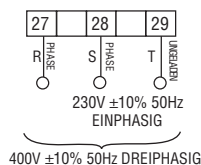

FUNKTIONEN

Automatisch/Halbautomatisch:



DIP-SCHALTER 3

ON: Automatisches Schliessen
 3 OFF: Kein automat. Schliessen

Gehürfunktion:

Trimmer T3 von 3 bis 30 s wird durch eine Impulsgabe (auch Funkimpuls), länger als 2s betätigt

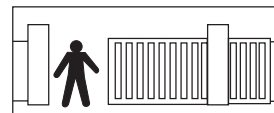
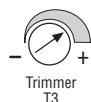

Totmann-Bedienung:

DIP-SCHALTER 6

ON: Totmann-Bedienung mit Dip-Schalter 4=OFF und Dip-Schalter 3=OFF
 6 OFF: Normale Funktion

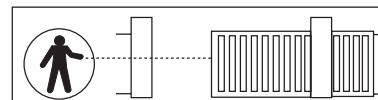

Diagnose-Leds:

- L1 = Unter 230V 50Hz Versorgungsspannung. Erleuchtet
- L2 = Lichtschranke. Erlischt wenn ein Hindernis den Lichtstrahl unterbricht
- L3 = Öffnen. Erleuchtet bei einer Auf-Impulsgabe
- L4 = Schliessen. Erleuchtet bei einer Zu-Impulsgabe
- L5 = Halt. Erlischt bei einer Stopp-Impulsgabe
- L6 = Funk. Erleuchtet bei jeder Impulsgabe des Senders
- L7 = Automation-Zustand. Blinkt während des Laufes
- L8 = Endschalter bei Schliessung. Aus, wenn das Tor geschlossen ist
- L9 = Endschalter bei Öffnung. Aus, wenn das Tor offen ist
- L10 = Erleuchtet nach der eingestellten Zeit des Trimmers T4

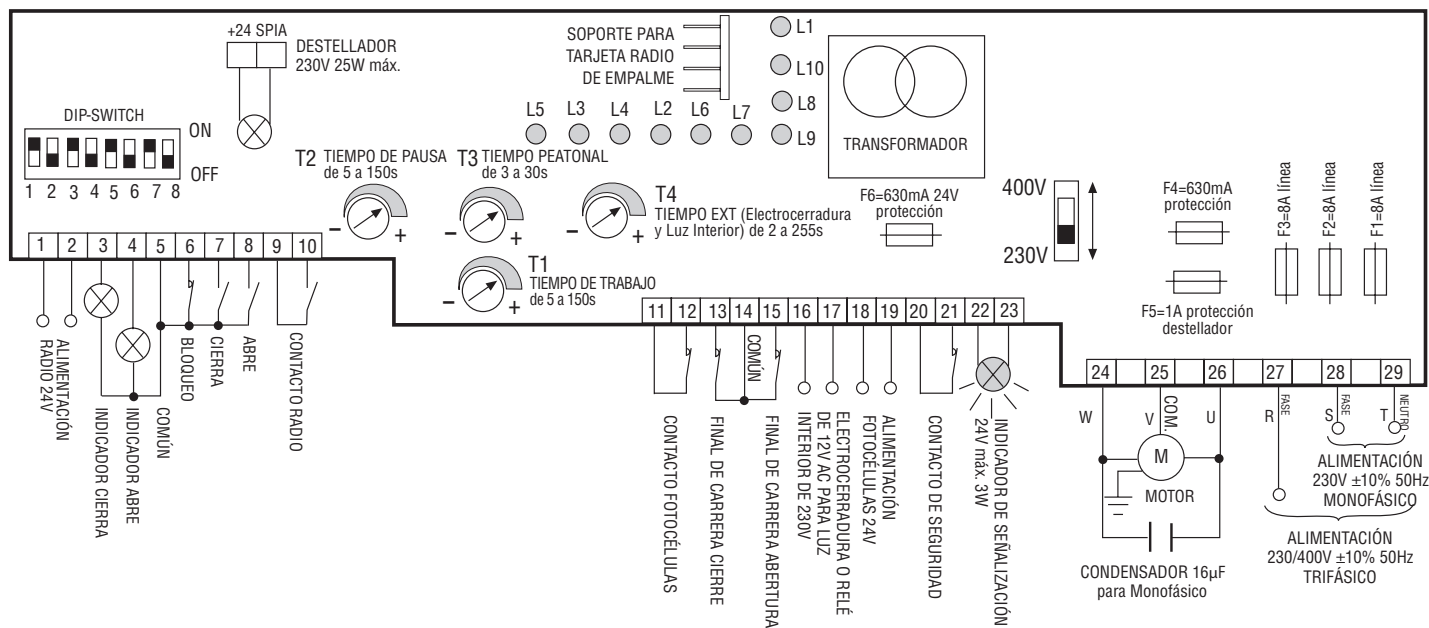

Descripción general: El programador Elpro 70/3 Plus de nueva generación, se emplea en los abre-verjas deslizantes MEC 200. Alimentado a 230V-400V monofásico y trifásico, cumple con las normativas de seguridad de Baja Tensión 2006/95/CE y Compatibilidad Electromagnética 2004/108/CEE - 92/31/CEE, se aconseja por lo tanto la instalación por parte de personal técnico cualificado respetando las normativas de seguridad vigentes. La Empresa fabricante no asume ninguna responsabilidad por el uso impropio del programador; además se reserva el derecho de aportar modificaciones y actualizaciones al presente manual y al programador. **El incumplimiento de las reglas de instalación puede generar serios daños a personas o cosas.**



IMPORTANTE:

- El programador se instala dentro de la automatización MEC 200.
 - Asegurarse que la alimentación del programador electrónico sea de 230V ±10% o bien de 400V ±10%.
 - Asegurarse que la alimentación al Motor Eléctrico sea de 230V ±10% o bien de 400V ±10%.
 - Para distancias superiores a los 50 metros aumentar la sección de los cables.
 - Aplicar un Interruptor Magneto-Térmico diferencial del tipo 0,03A de alta sensibilidad a la alimentación del programador.
 - Alimentación, Motor eléctrico, Destellador usar cables con cables internos de 1,5 mm² hasta 50m de distancia; para Finales de carrera y accesorios varios emplear cables con cables internos de 1mm².
 - Si no se usan las Fococélulas efectuar un puente entre los bornes 11 y 12.
 - Si no se usa ningún Tablero de pulsadores efectuar un puente entre los bornes 5 y 6.
- Nota:** Para aplicaciones como encendido luces, telecámaras, etc., utilizar Relé Estáticos para no generar interferencias en el microprocesador.

Dip-Switch:

- 1= ON Fococélula parada en abertura
- 2= ON Radio no invierte en abertura
- 3= ON Cierra en Automático
- 4= ON Pre-destello Activo
- 5= ON Radio paso-paso con bloqueo intermedio
- 6= ON Servicio hombre presente (Dip 4=OFF y Dip 3=OFF)
- 7= ON Destellador apagado durante la pausa en Automático
- 8= OFF, libre

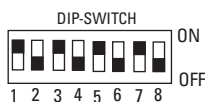

Ante la falta de funcionamiento:

- Asegurarse que la alimentación del programador electrónico sea de 230V ±10% o bien de 400V ±10%
- Asegurarse que la alimentación al Motor Eléctrico sea de 230V ±10% o bien de 400V ±10%
- Para distancias superiores a los 50 metros aumentar la sección de los cables.
- Controlar los fusibles
- Controlar que las Fococélulas estén con contacto cerrado.
- Controlar todos los contactos cerrados NC
- Controlar que no haya una caída de tensión entre el programador y el motor eléctrico.



CONEXIONES ELÉCTRICAS EN BAJA TENSIÓN

Fotocélulas:

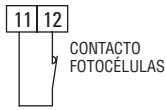

DIP-SWITCH 1:

- ON: Fococélula parada en abertura e invierte en cierre por obstáculo removido
- 1 OFF: Fococélula no parada en abertura e invierte en cierre en presencia de obstáculo

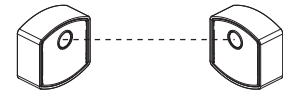

Selectores llav:

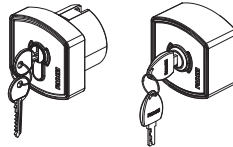
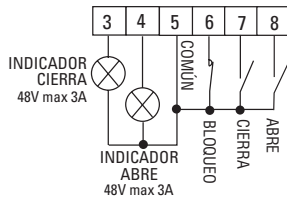

Final de carrera:

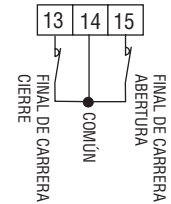

Contacto Radio:

- Abre/Cierra (normal)
- Inversión de marcha en cada impulso
- Paso Paso 2

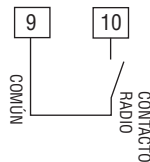

DIP-SWITCH 2 y 5 (NUNCA deben estar al mismo tiempo en ON):

- ON: No invierte en abertura
- 2 OFF: Invierte la marcha a cada impulso

- ON: Paso paso con bloqueo intermedio
- 5 OFF: Funcionamiento normal

Indicador 24V 3W de Señalización:

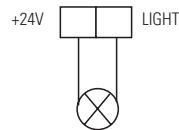

- Indicador **Encendido** = Verja Abierta
- Indicador **Apagado** = Verja Cerrada
- Parpadea a **0,5s (veloz)** = movimiento de cierre
- Parpadea a **1s (normal)** = movimiento de abertura
- Parpadea a **2s (lento)** = automatización bloqueada

Alimentación Radio:



Contacto de seguridad:



Electrocerradura:

Regular el Trimmer T4 al mínimo, la Electrocerradura permanece excitada durante 2 segundos

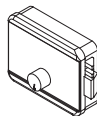

Luz interior:

Conectar un Relè modular de 24VCA (Trimmer T4 de 2s a 255s) para hacer funcionar una lámpara a 230V



CONEXIONES ELÉCTRICAS DE POTENCIA

Motor Monofásico (230V) y Trifásico (400V):

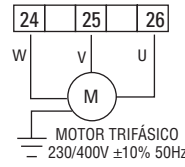
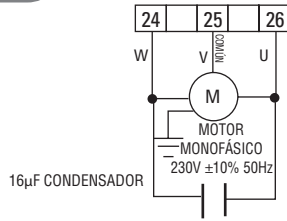

Destellador:

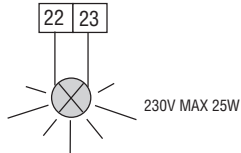

DIP-SWITCH 4 y 7:

ON: Pre-destello
OFF: Sin pre-destello
4

ON: Destellador Desactivado durante la pausa en automático.
7 OFF: Destella durante la pausa en automático

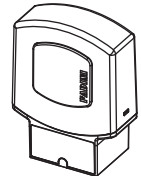

Alimentación:

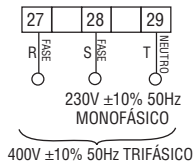

FUNCIONES

Automático/ Semiautomático:



DIP-SWITCH 3

ON= Cierra en Automático
OFF= No cierra en Automático
3

Abertura Peatonal:

Trimmer T3 de 3 a 30s. Se activa con un impulso de mando (también de radio), con una duración superior a los 2s

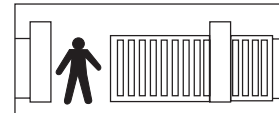
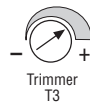

Hombre Presente:

DIP-SWITCH 6

ON= Hombre Presente con Dip-switch 4=OFF y Dip-switch 3=OFF
OFF= Funcionamiento Normal
6

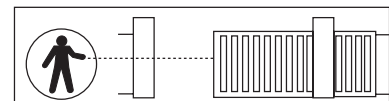

Led de Diagnóstico:

- L1 = Alimentación 230V 50Hz está encendido
- L2 = Fococélulas, se apaga con obstáculo presente
- L3 = Abre, se ilumina por impulso del mando de apertura
- L4 = Cierra, se ilumina por impulso del mando de cierre
- L5 = Bloqueo, se apaga por impulso del mando stop
- L6 = Radio, se ilumina en cada impulso del transmisor
- L7 = Estado de la automatización, parpadea durante el movimiento
- L8 = Final de carrera cierra, apagado con verja cerrada
- L9 = Final de carrera abre, apagado con verja abierta
- L10 = Se enciende durante el tiempo programado por el Trimmer T4

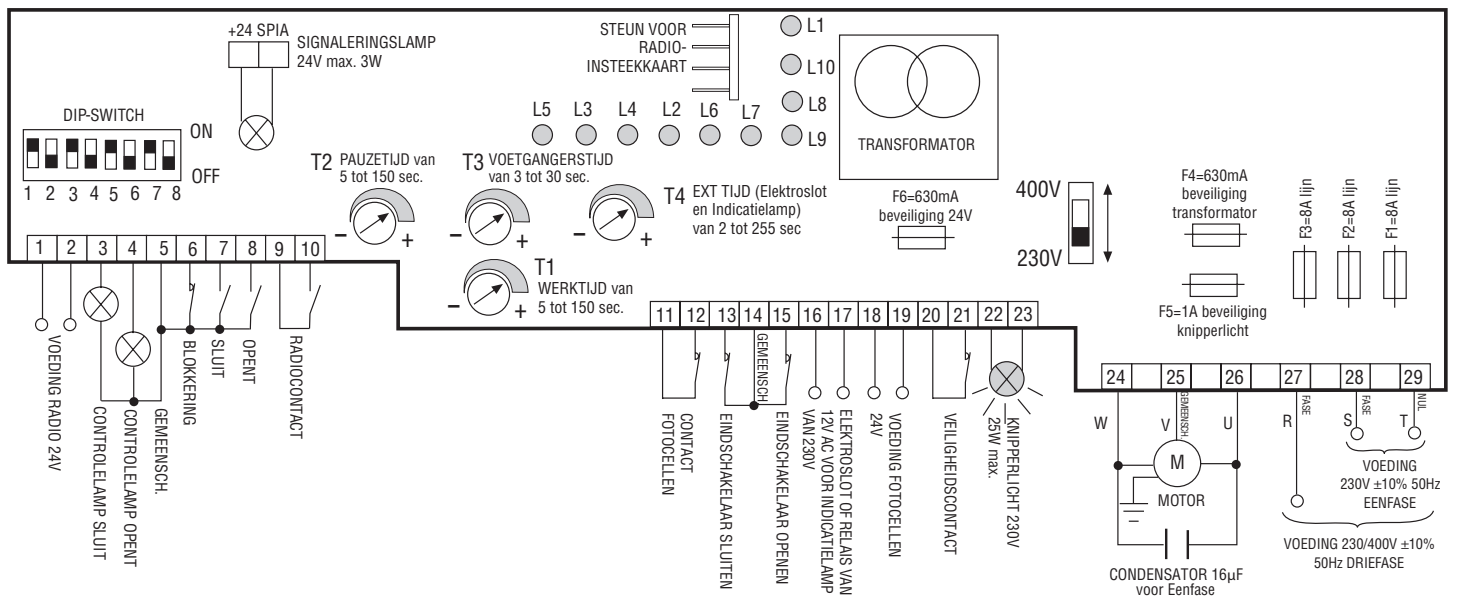

Algemene beschrijving: De programmeerinrichting Elpro 70/3 Plus van de nieuwste generatie wordt gebruikt voor de schuifhekopeners MEC 200. De inrichting wordt gevoed met eenfase en driefase 230V-400V en voldoet aan de veiligheidsvoorschriften voor Laagspanning 2006/95/EG en Elektromagnetische Compatibiliteit 2004/108/EEG - 92/31/EEG. Om die reden adviseert men om de installatie door vakkundig technisch personeel volgens de geldende veiligheidsvoorschriften te laten uitvoeren. De fabrikant wijst alle aansprakelijkheid af voor het oneigenlijke gebruik van de programmeerinrichting. Bovendien behoudt men zich het recht voor om wijzigingen aan dit boekje en aan de programmeerinrichting aan te brengen. **Het niet in acht nemen van de installatievoorschriften kan ernstige schade aan zaken en personen veroorzaken.**



BELANGRIJK:

- De programmeerinrichting is in de automatisering MEC 200 geïnstalleerd.
 - Ga na dat de toevoer naar de elektronische programmeereenheid 230V ±10% of 400V ±10% is.
 - Ga na dat de toevoer naar de Elektrische Motor 230V ±10% of 400V ±10% is.
 - Voor afstanden die de 50 meter overschrijden moet de draaddoorsnede worden vergroot.
 - Breng een magnetothermische differentiaalschakelaar van het type 0,03 A met hoge gevoeligheid op de voeding van de programmeerinrichting aan.
 - Gebruik voor voeding, elektromotor en knipperlicht kabels met draden van 1,5 mm² tot 50 m afstand. Gebruik voor eindschakelaars en diverse accessoires kabels met draden van 1 mm².
 - Als geen fotocellen worden gebruikt, breng dan een brug tussen de klemmen 11 en 12 aan.
 - Als geen bedieningspaneel wordt gebruikt, breng dan een brug tussen de klemmen 5 en 6 aan.
- N.B. Gebruik voor toepassingen als inschakeling van lichten, televisiecamera's, enz., statische relais om geen storingen voor de microprocessor te produceren.

Dip-Switches:

- 1= ON Fotocel, stopt tijdens openen
- 2= ON Radio, keert niet om tijdens openen
- 3= ON Sluit in automatisch
- 4= ON Vooraf-knipperen actief
- 5= ON Radio stap-voor-stap met tussenblokkering
- 6= ON Dodemansfunctie (Dip 4=OFF en Dip 3=OFF)
- 7= ON Knipperlicht uit tijdens pauze in Automatisch
- 8= OFF, vrij



Indien de inrichting niet werkt:

- Ga na dat de toevoer naar de elektronische programmeereenheid 230V ±10% of 400V ±10% is.
- Ga na dat de toevoer naar de Elektrische Motor 230V ±10% of 400V ±10% is.
- Voor afstanden die de 50 meter overschrijden moet de draaddoorsnede worden vergroot.
- Controleer de zekeringen
- Controleer of de fotocellen een gesloten contact hebben
- Controleer alle gesloten contacten (N.C.)
- Controleer of er geen spanningsval tussen programmeerinrichting en elektromotor is

ELEKTRISCHE LAAGSPANNINGSAANSLUITINGEN

Fotocellen:

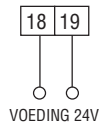
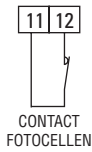

DIP-SWITCH 1:

- ON: Fotocel stopt tijdens openen en keert om tijdens sluiten bij verwijderd obstakel
- 1 OFF: Fotocel stopt niet tijdens openen en keert om tijdens sluiten bij aanwezigheid van obstakel

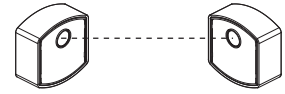

Sleutelkiezer:

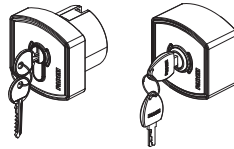
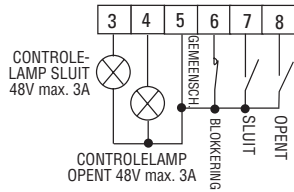

Eindschakelaars:

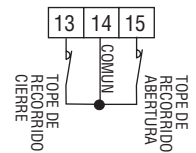

Radiocontact:

- Opent/sluit (normaal)
- Omkering richting bij elke impuls
- Stap-voor-stap

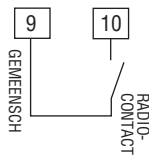

DIP-SWITCH 2 en 5 (mogen NOOIT gelijktijdig ON zijn):

- ON: Keert niet om tijdens openen
- 2 OFF: Keert richting bij elke impuls om

- ON: Stap voor stap met tussenblokkering
- 5 OFF: Normale werking

Signaleringslamp 24V 3W:

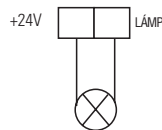

- Lamp **Aan** = Hek open
- Lamp **Uit** = Hek gesloten
- Knippert met **0,5s (snel)** = sluitbeweging
- Knippert met **1s (normaal)** = openende beweging
- Knippert met **2s (langzaam)** = automatisering in blokkering

Radiovoeding:

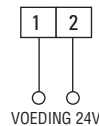

Veiligheidscontact:



Elektroslot:

Regel de trimmer T4 op het minimum af, het elektroslot blijft 2 seconden bekrachtigd

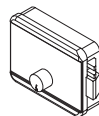

Indicatielamp:

Sluit een modulaar relais van 24VCA (Trimmer T4 van 2 tot 255 sec.) aan om een lamp van 230V te laten werken

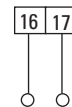

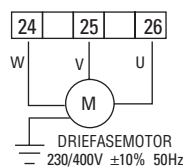
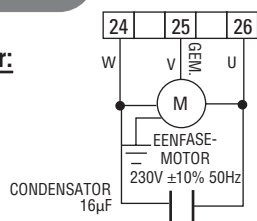

ELEKTRISCHE HOOGSPANNINGSAANSLUITINGEN
Eenfase- (230V) en driefase-(400V) motor:

T1 WERKTIJD OPENT / SLUIT VAN 5 TOT 150 sec.

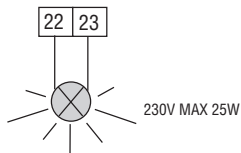

T2 PAUZETIJD VAN 5 TOT 150 sec.

Knipperlicht:

DIP-SWITCH 4 en 7:

ON: Vooraf-knipperen
 OFF: Zonder vooraf-knipperen
4

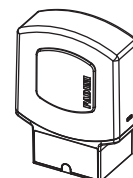
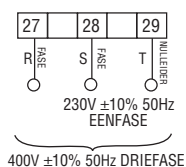
ON: Knipperlicht geïnactiveerd tijdens de pauze in automatisch
 OFF: Knippert tijdens de pauze in automatisch
7

Voeding:

FUNCTIES
Automatisch/Halfautomatisch:

T2 Pauzetijd van 5 tot 128 sec.

DIP-SWITCH 3

ON: Sluit in Automatisch
 OFF: Sluit niet in Automatisch
3

Voetgangersdoorgang:

Trimmer T3 van 3 tot 30 sec. Activeerbaar met een stuurimpuls (ook radio), met een duur van meer dan 2 sec.

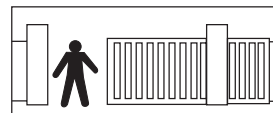

Trimmer T3

Dodeman:
DIP-SWITCH 6

ON: Dodeman met Dip-switch 4=OFF en Dip-switch 3=OFF
 OFF: Normale werking
6

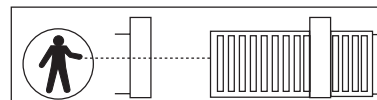
Diagnoseleds:

- L1 = Voeding 230V 50Hz is ingeschakeld
- L2 = Fotocellen, gaat uit bij obstakel aanwezig
- L3 = Opent, gaat branden bij impuls van opencommando
- L4 = Sluit, gaat branden bij impuls van sluitcommando
- L5 = Blokkering, gaat uit bij impuls van stopcommando
- L6 = Radio, gaat branden bij elke impuls van de zender
- L7 = Status van automatisering, knippert tijdens de beweging
- L8 = Eindschakelaar sluit, uit bij gesloten hek
- L9 = Eindschakelaar opent, uit bij gesloten hek
- L10 = Gaat branden gedurende de tijd ingesteld door Trimmer T4

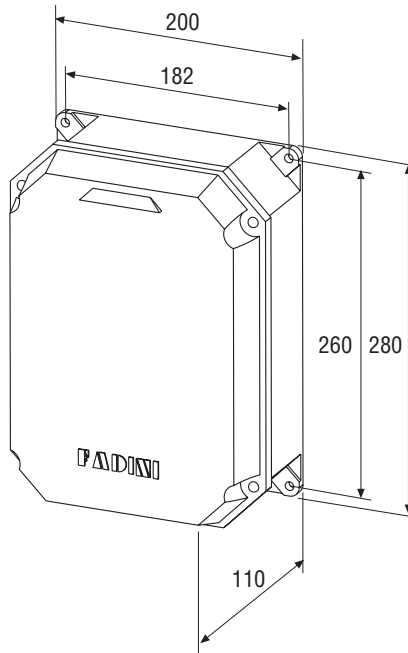

- I** - Prima dell'installazione da parte di personale tecnico qualificato, si consiglia di prendere visione del Libretto Normative di Sicurezza che la Meccanica Fadini mette a disposizione.
- GB** - Please note that installation must be carried out by qualified technicians following Meccanica Fadini's Safety Norms Manual.
- F** - L'installation doit être effectuée par un technicien qualifié suivant le manuel des Normes de Sécurité de Meccanica Fadini.
- D** - Vor der Montage durch einen Fachmann, wird es empfohlen die Anleitung zur Sicherheitsnormen, die Meccanica Fadini zur Verfügung stellt, nachzulesen.
- E** - Antes de la instalación por el personal técnico calificado, se recomienda leer detenidamente el Folleto de la Reglamentación de Seguridad que la empresa Meccanica Fadini pone a su disposición.
- NL** - Voordat de installatie door gekwalificeerd technisch personeel wordt uitgevoerd, wordt geadviseerd om het boekje met veiligheidsvoorschriften dat Meccanica Fadini ter beschikking stelt door te lezen.



I Direttiva **2003/108/CE**
Smaltimento dei materiali
elettrici ed elettronici

**VIETATO GETTARE NEI RIFIUTI
MATERIALI NOCIVI PER L'AMBIENTE**

GB **2003/108/CE** Directive
for waste electrical and
electronic equipments

**DISPOSE OF PROPERLY
ENVIRONMENT-NOXIOUS MATERIALS**



**Via Mantova, 177/A - 37053 Cerea (Verona) Italy - Tel. +39 0442 330422 r.a. - Fax +39 0442 331054
e-mail: info@fadini.net - www.fadini.net**