

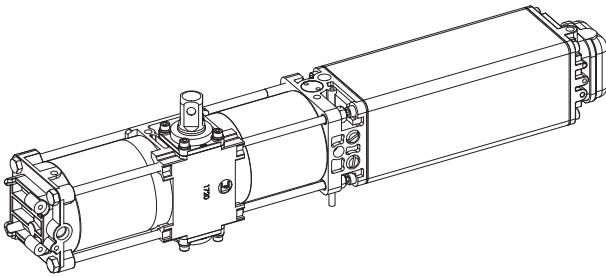

APROLI 380 LB

Oil-hydraulic operator for bi-parting double folding doors



**APROLI 380 LB
RIGHT-HAND**

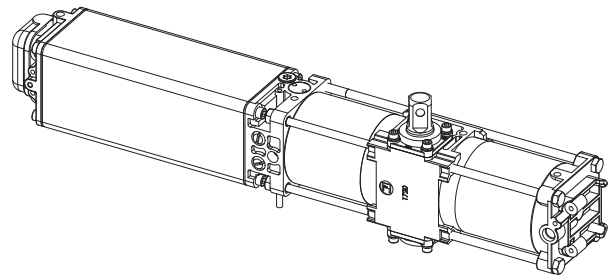

**APROLI 380 LB
LEFT-HAND**

GENERAL WARNINGS FOR PEOPLE SAFETY

THANK YOU

Thank you for purchasing a Fadini product. Please read these instructions carefully before using this appliance. The instructions contain important information which will help you get the best out of the appliance and ensure safe and proper installation, use and maintenance. Keep this manual in a convenient place so that you can always refer to it for the safe and proper use of the appliance.

INTRODUCTION

This operator is designed for a specific scope of applications as indicated in this manual, including safety, control and signaling accessories as minimum required with Fadini equipment. □ Any applications not explicitly included in this manual may cause operation problems or damages to properties and people. □ Meccanica Fadini S.r.l. is not liable for damages caused by the incorrect use of the equipment, or for applications not included in this manual or for malfunctioning resulting from the use of materials or accessories not recommended by the manufacturer. □ The manufacturer reserves the right to make changes to its products without prior notice. □ All that is not explicitly indicated in this manual is to be considered not allowed.

BEFORE INSTALLATION

Before commencing operator installation assess the suitability of the access, its general condition and the structure. □ Make sure that there is no risk of impact, crushing, shearing, conveying, cutting, entangling and lifting situations, which may prejudice people safety. □ Do not install near any source of heat and avoid contacts with flammable substances. □ Keep all the accessories able to turn on the operator (transmitters, proximity readers, key-switches, etc) out of the reach of the children. □ Transit through the access only with stationary operator. □ Do not allow children and/or people to stand in the proximity of a working operator. □ To ensure safety in the whole movement area of a gate it is advisable to install photocells, sensitive edges, magnetic loops and detectors. □ Use yellow-black strips or proper signals to identify dangerous spots. □ Before cleaning and maintenance operations, disconnect the appliance from the mains by switching off the master switch. □ If removing the actuator, do not cut the electric wires, but disconnect them from the terminal box by loosening the screws inside the junction box.

INSTALLATION

All installation operations must be performed by a qualified technician, in observance of the Machinery Directive 2006/42/CE and safety regulations EN 12453 - EN 12445. □ Verify the presence of a thermal-magnetic circuit breaker 0,03 A - 230 V - 50 Hz upstream the installation. □ Use appropriate objects to test the correct functionality of the safety accessories, such as photocells, sensitive edges, etc. □ Carry out a risk analysis by means of appropriate instruments measuring the crushing and impact force of the main opening and closing edge in compliance with EN 12445. □ Identify the appropriate solution necessary to eliminate and reduce such risks.

□ In case where the gate to automate is equipped with a pedestrian entrance, it is appropriate to prepare the system in such a way to prohibit the operation of the engine when the pedestrian entrance is used. □ Apply safety nameplates with CE marking on the gate warning about the presence of an automated installation. □ The installer must inform and instruct the end user about the proper use of the system by releasing him a technical dossier, including: layout and components of the installation, risk analysis, verification of safety accessories, verification of impact forces and reporting of residual risks.

INFORMATION FOR END-USERS

The end-user is required to read carefully and to receive information concerning only the operation of the installation so that he becomes himself responsible for the correct use of it. □ The end-user shall establish a written maintenance contract with the installer/maintenance technician (on -call). □ Any maintenance operation must be done by qualified technicians. □ Keep these instructions carefully.

WARNINGS FOR THE CORRECT OPERATION OF THE INSTALLATION

For optimum performance of system over time according to safety regulations, it is necessary to perform proper maintenance and monitoring of the entire installation: the automation, the electronic equipment and the cables connected to these. □ The entire installation must be carried out by qualified technical personnel, filling in the Maintenance Manual indicated in the Safety Regulation Book (to be requested or downloaded from the site www.fadini.net/supporto/downloads). □ Operator: maintenance inspection at least every 6 months, while for the electronic equipment and safety systems an inspection at least once every month is required. □ The manufacturer, Meccanica Fadini S.r.l., is not responsible for non-observance of good installation practice and incorrect maintenance of the installation.

DISPOSAL OF MATERIALS

Dispose properly of the packaging materials such as cardboard, nylon, polystyrene etc. through specializing companies (after verification of the regulations in force at the place of installation in the field of waste disposal). Disposal of electrical and electronic materials: to remove and dispose through specializing companies, as per Directive 2012/19/UE. Disposal of substances hazardous for the environment is prohibited.



CE DECLARATION OF CONFORMITY of the manufacturer:

Meccanica Fadini S.r.l. (Via Mantova, 177/A - 37053 Cerea - VR - Italy) declares under own responsibility that: **APROLI 380 LB** complies with the 2006/42/CE Machinery Directive, and also that it is sold to be installed in an "automatic system", along with original accessories and components as indicated by the manufacturing company. An automatic gate operator is, by law, a "machinery" and therefore the installer must fit the equipment with all of the applicable safety norms. The installer is also required to issue the installer's Declaration of Conformity. The manufacturer is not liable for possible incorrect use of the product. The product complies with the following specific norms: analysis of the risks and subsequent action to cure them as per EN 12445 and EN 12453, Low Voltage Directive 2014/35/UE, Electromagnetic Compatibility 2014/30/UE. In order to certify the product, the manufacturer declares under own responsibility the compliance with the EN 13241-1 PRODUCT NORMS.

Meccanica Fadini S.r.l.
Director in charge



GENERAL DESCRIPTION OF THE PRODUCT

Aproli 380 LB is an oil-hydraulic operator designed for on-the-door mounting, fitted with a sliding arm made of zinc-coated steel, designed for opening and closing single or double folding gates and industrial doors mounted on sliding tracks.

Aproli 380 LB is a handed unit and therefore there are two versions of it (*right* and *left*), depending on which door panel it is to be fitted either to the first or the second one.

It is an oil-hydraulic product and has all the advantages that such technology can ensure ie. reliability, smooth movements, adjustable thrust power by pressure valves and adaptability to most doors of the indicated type (max. weight 250 kg). Easy to install by means of a support bracket made of zinc coated steel and to be fixed by expanding bolts; the operator assembly, in zinc coated steel and aluminium, is designed to fit into it and be fastened by screws.

The movement shaft is made of hardened steel to ensure reliability and last longer over the time.

The movement arm system consists of a bar sliding into a tubular casing, both made of zinc coated steel.

This operator is double locking being fitted with a hydraulic valve device to lock the door in both directions.

For Aproli 380 LB to be electrically operated, it is required that an electronic control board type Elpro 27 be connected to it and located in a sheltered place, allowing for all the pre-set operations be performed in automatic or semiautomatic modes.

A number of accessories can be connected to ensure safety and proper functioning and turn this operator into a most versatile unit able to meet both public and private applications.

Pressure adjustment to minimum and maximum values, as well as manual release, are made possible by a valve system.

COMPONENTS

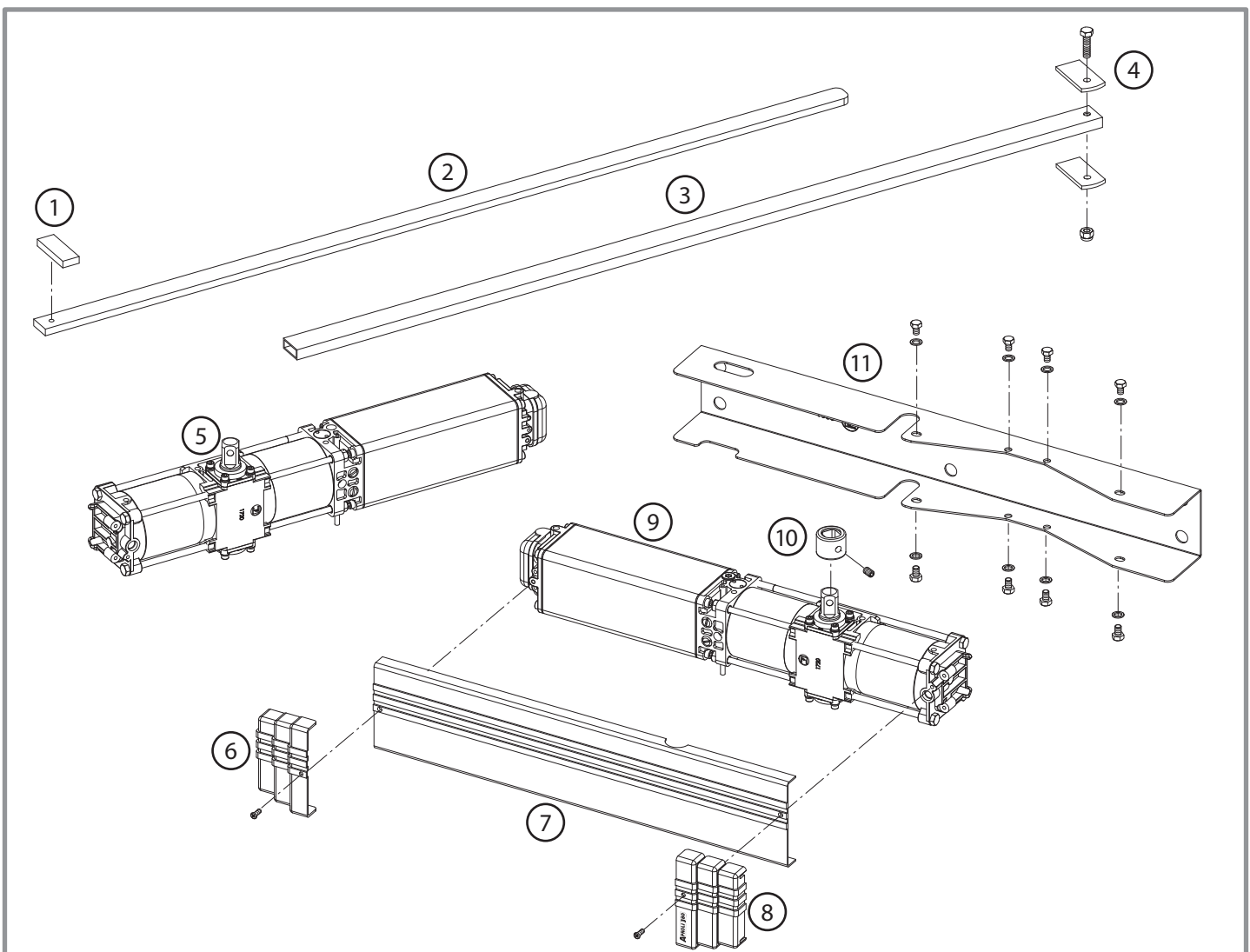

- 1 - Stop plate 30x10x100
- 2 - Sliding bar 30x10x1.200
- 3 - Tubular bar 35x15x1.200
- 4 - Pre-bored fixing plates
- 5 - Right-handed Aproli 380 LB
- 6 - Left end cover (optional)

- 7 - Protection cover (optional)
- 8 - Right end cover (optional)
- 9 - left-handed Aproli 380 LB
- 10 - Square-holed ferrule
- 11 - Fixing bracket

Pic. 1

ELECTRICAL GENERAL WIRING DIAGRAM AND COMPONENTS LAYOUT

Indicative general layout: it is the installer's care and responsibility to lay the tubes for the connections in the most suitable way.

English

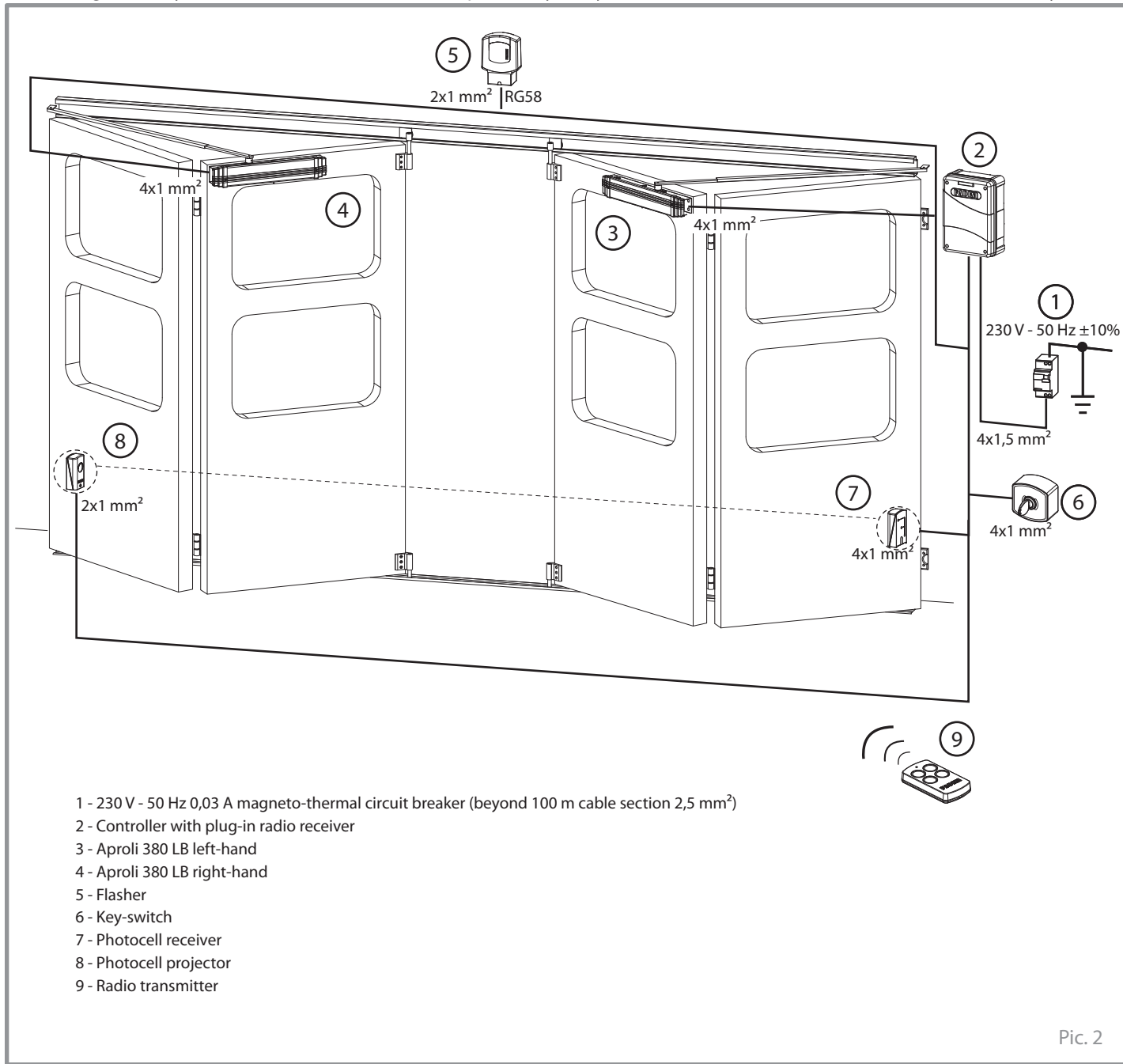

- 1 - 230 V - 50 Hz 0,03 A magneto-thermal circuit breaker (beyond 100 m cable section 2,5 mm²)
- 2 - Controller with plug-in radio receiver
- 3 - Aproli 380 LB left-hand
- 4 - Aproli 380 LB right-hand
- 5 - Flasher
- 6 - Key-switch
- 7 - Photocell receiver
- 8 - Photocell projector
- 9 - Radio transmitter

Pic. 2

IDENTIFYING APROLI 380 LB

Whenever Aproli 380 LB is installed on a folding door, make sure the rotation shaft is always looking upwards. In this position, the adjustment valves are in the front side, whereas the release lever is in the bottom side as it should be.

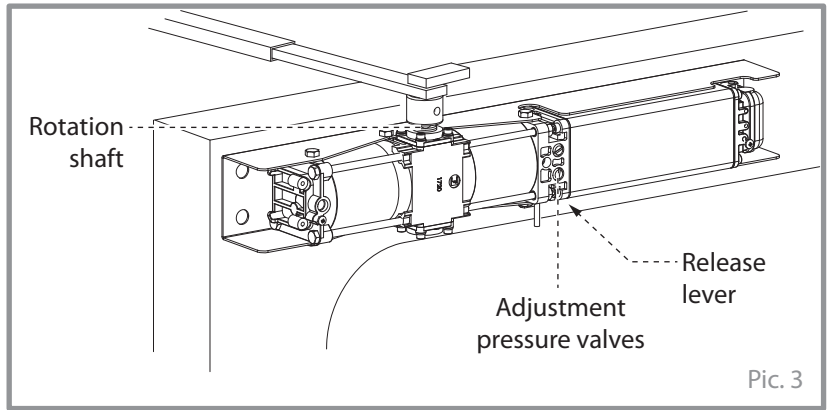

English



NOTE WELL: depending on which panel Aproli 380 LB is installed (either panel 1 or 2), the operator handing version (right or left) changes, as indicated in Pic. 4.

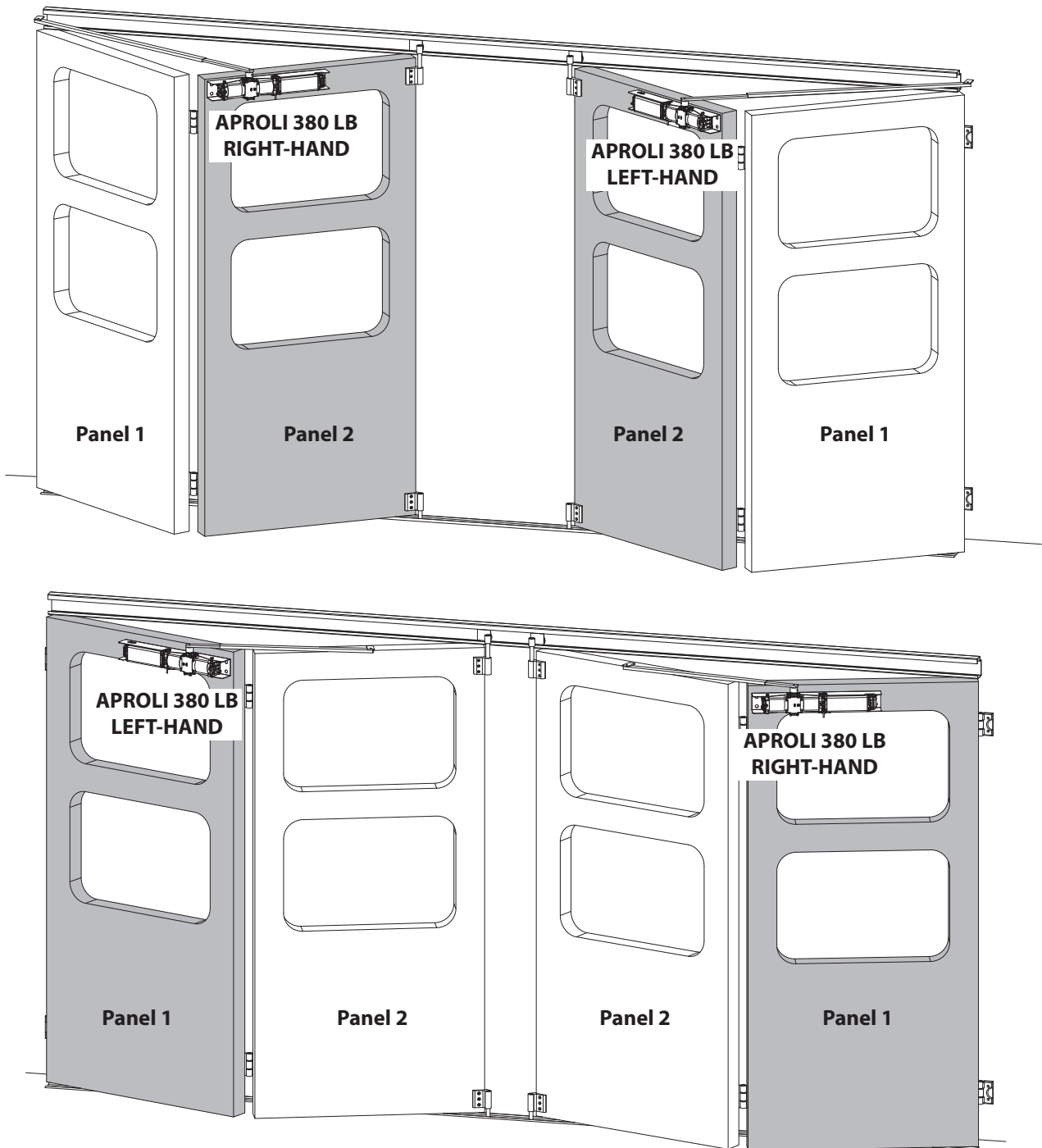

INSTALLATION DISTANCES

Depending on which door panel Aproli 380 LB is fitted (either panel 1 or 2 of the folding door), it may be required that the driving arm, consisting of a bar sliding into a tube, standard length 1,2 m each, be cut to a proper measure (see the table below). The two elements, bar and tube, make up a single telescopic arm to operate the doors. The measurements in the table are such to provide a proper coupling allowing the movement of the doors.

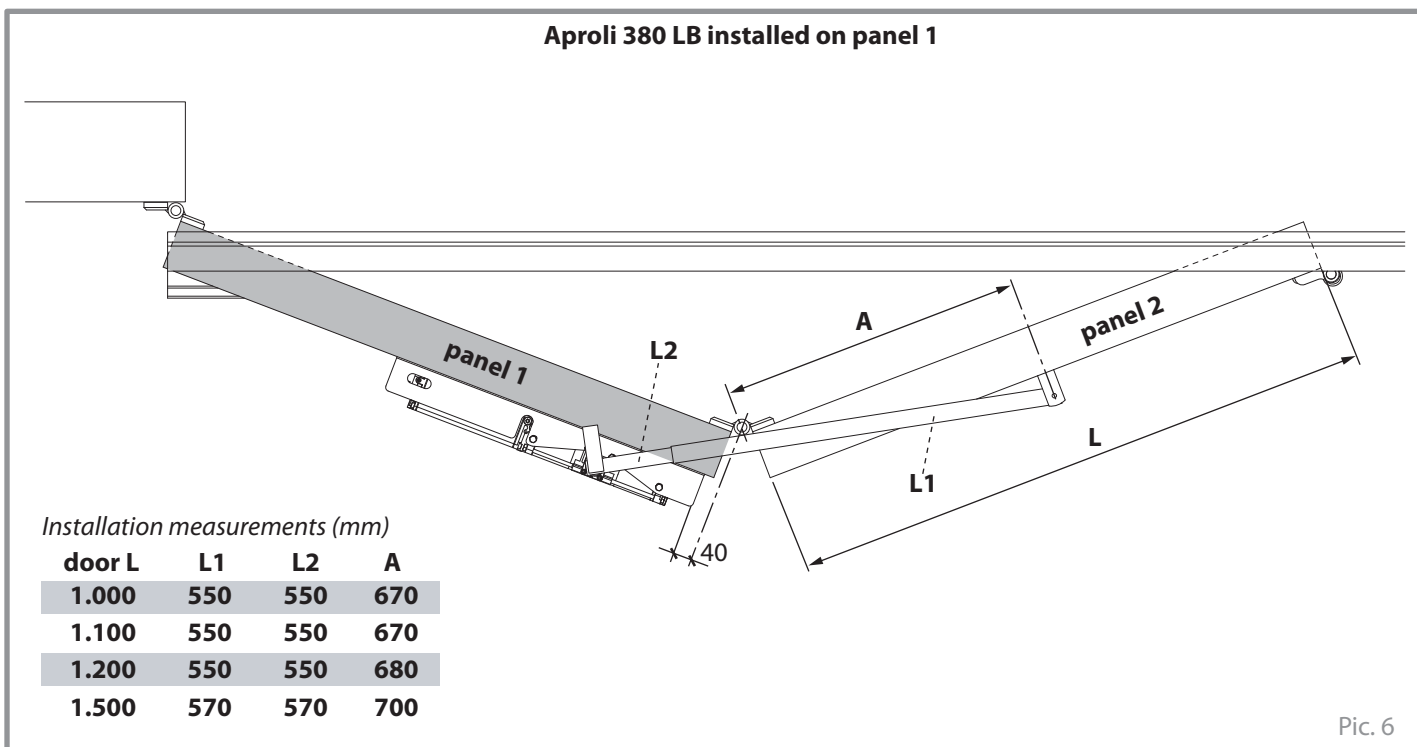
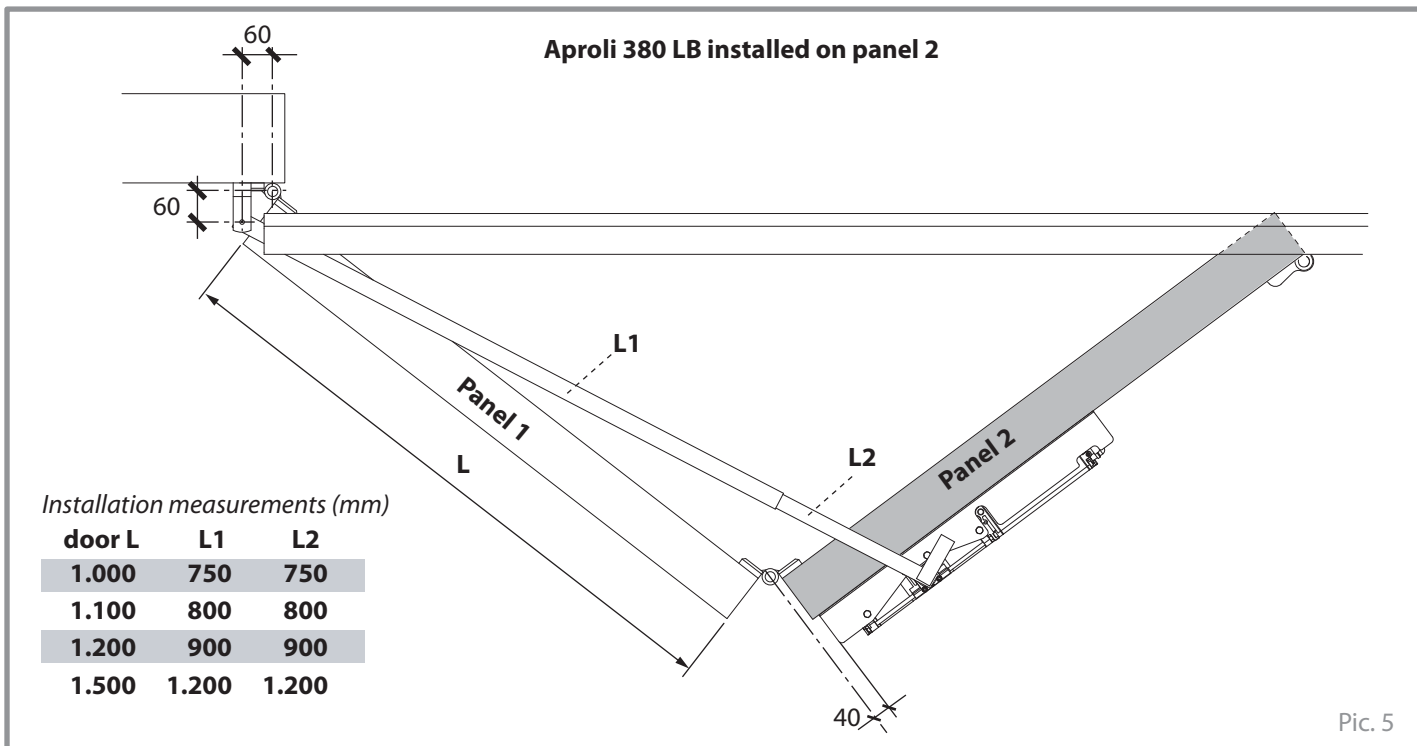

The bar and tube of the telescopic arm are required to be cut to L1 and L2 measurements. It is important that the sliding bar be cut (shortened) so that the end with rounded corners be preserved, to facilitate sliding into the tubular element (Pic. 7).

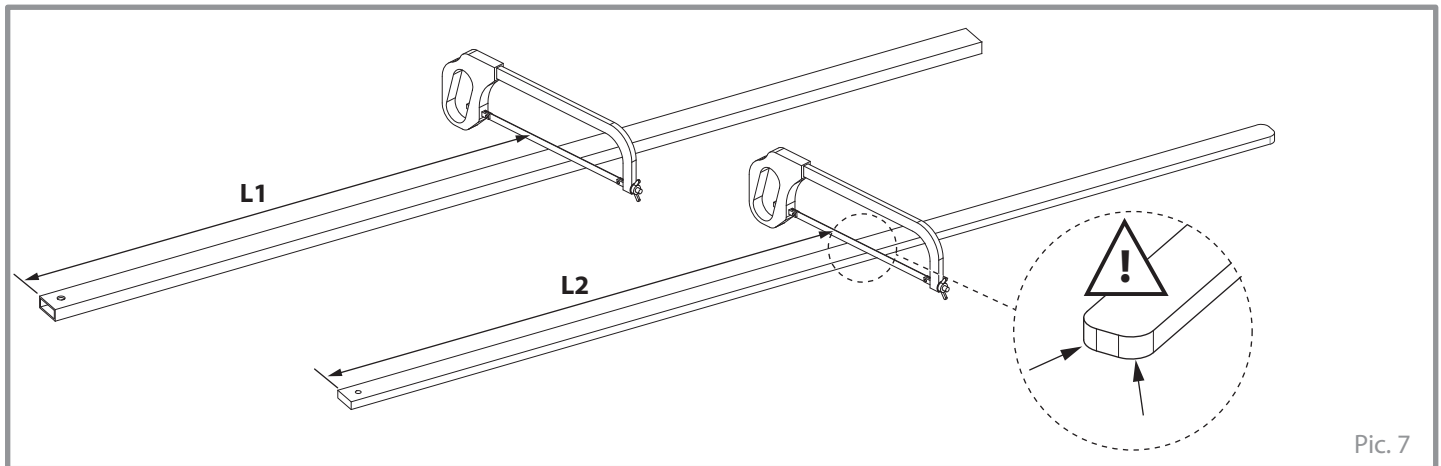

FIXING APROLI 380 LB ON TO THE DOOR

Install the support bracket by means of bolts or screws, depending on the door construction, making sure it is fixed to a solid element of the door frame, in such a position that the telescopic arm, once mounted to it, be free to move above the door top (Pic. 8).

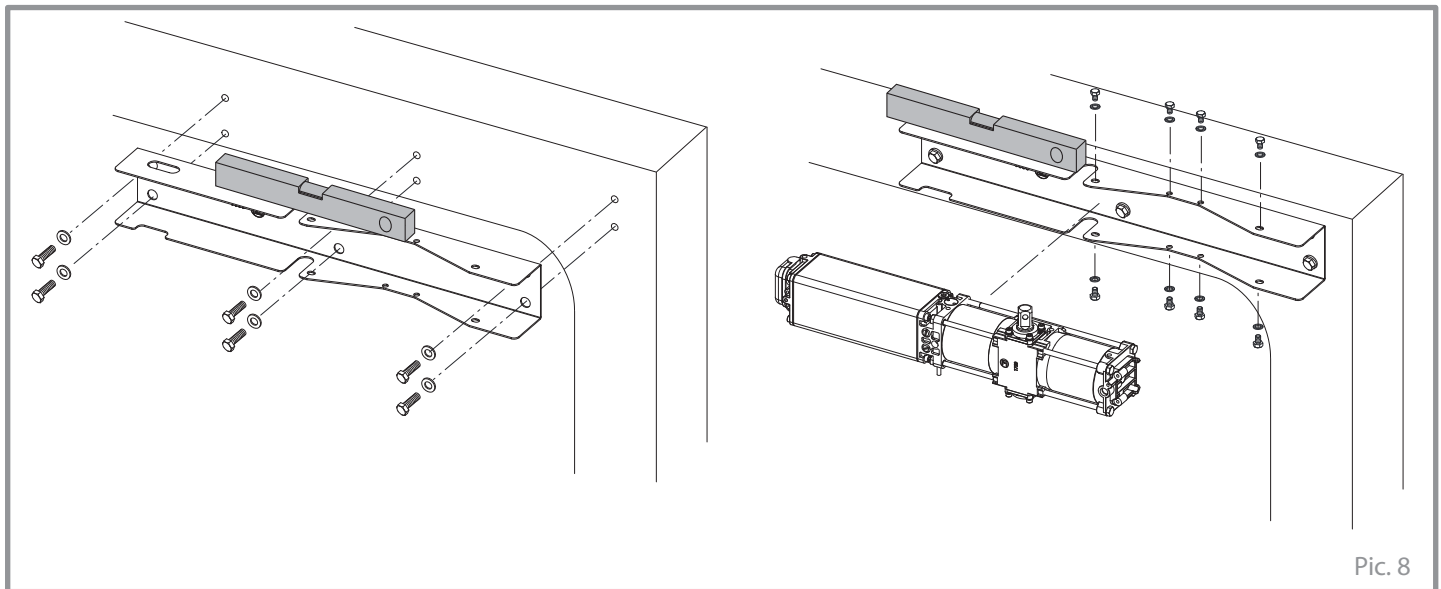

ELECTRIC POWER SUPPLY TO THE MOTOR

Remove the cover protecting the inner terminal block to be able to connect the power supply cables (Pic. 9).

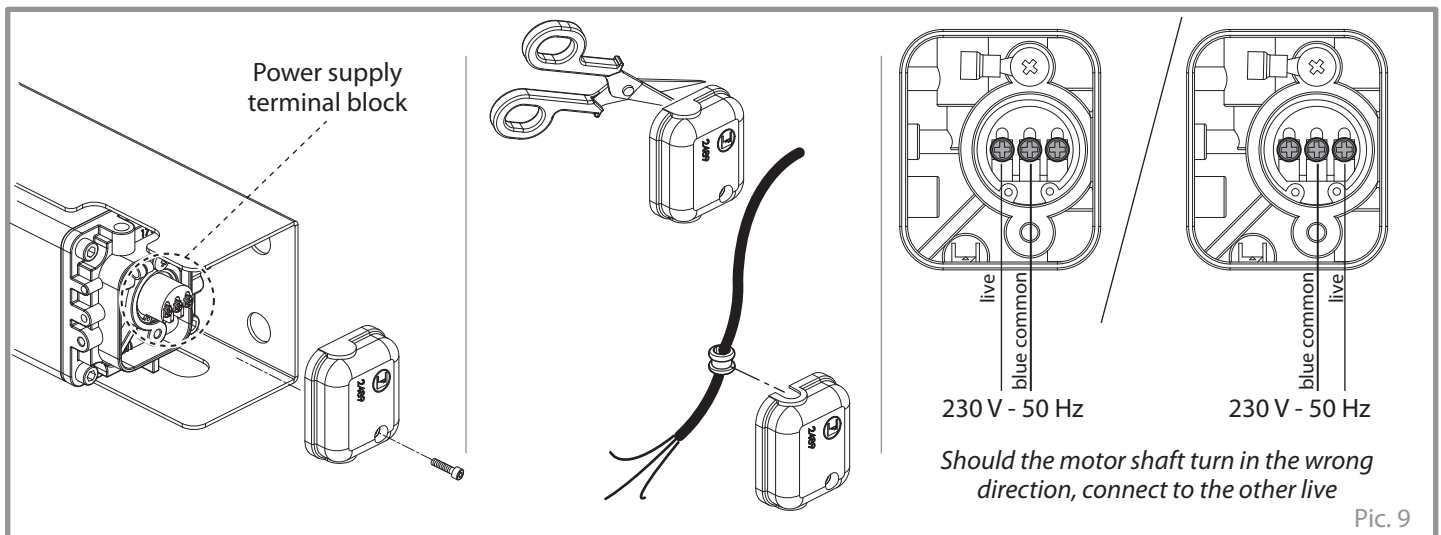

English

FIXING THE TELESCOPIC ARM TO THE FERRULE WITH SQUARE HOLE

Supply the electric motor with power (230 V - 50 Hz) to allow the first running test.

As a factory standard, Aproli 380 LB, either right- or left-handed, is supplied with the motor square shaft rotated to the end of the permitted stroke, to be installed on to a door in fully closed position (either on panel 1 or panel 2).

For the door to stay perfectly locked in closed position, the rotation shaft is not to be at the end of the stroke (as it comes from the factory), therefore it should be rotated **at least 5°** approximately to the other way, to ensure in this way that Aproli 380 LB keeps pushing the door to close (Pic. 10).

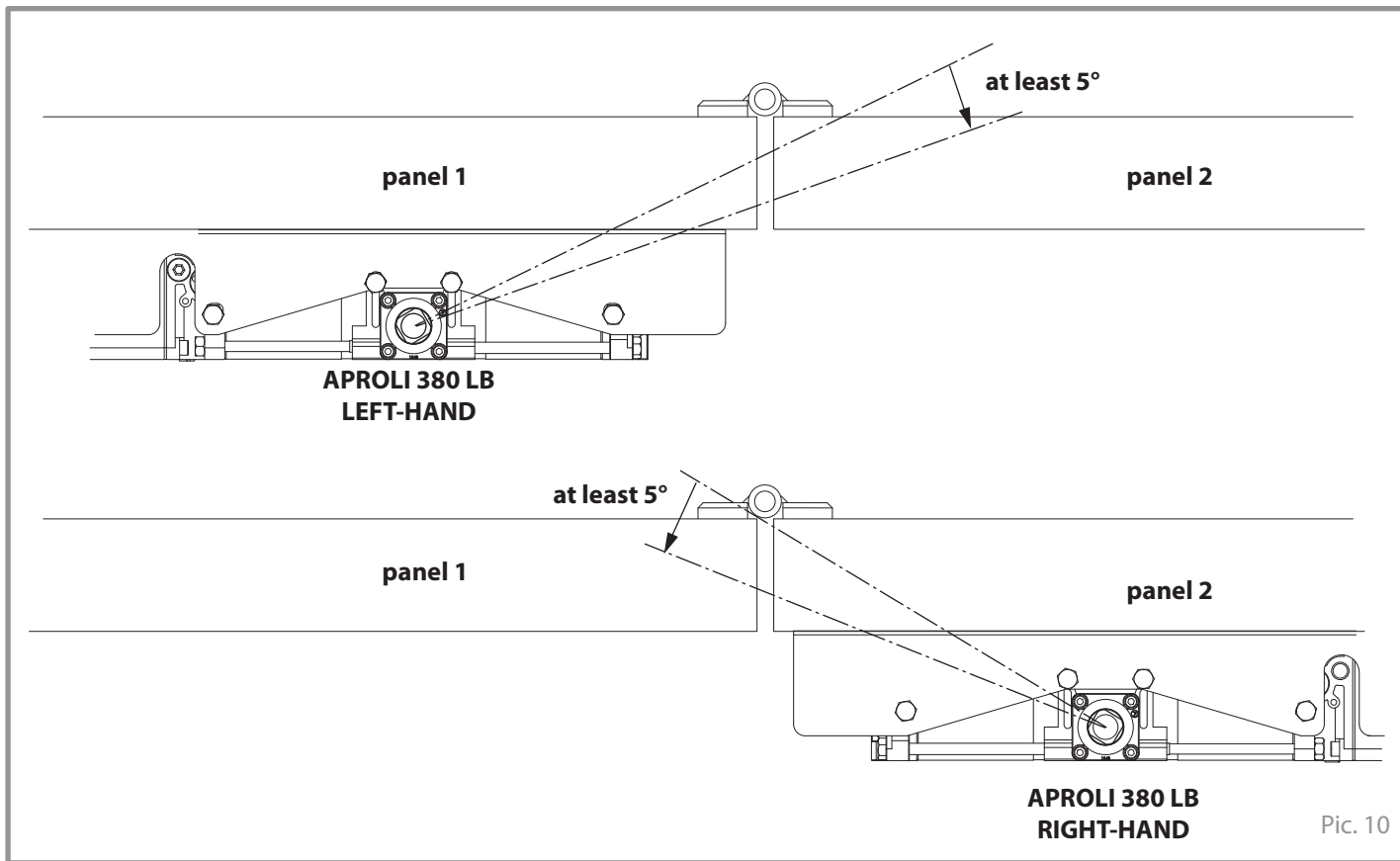

Fit the square-holed ferrule to the motor shaft and fasten it by the retaining pin matching the hole in the shaft. After rotating the ferrule 5° at least in the direction indicated in Pic. 10, weld the sliding bar on to the top of it making sure the bar and the shaft hole are aligned, in the direction of the wall fixing plate (Pic. 11).

NOTE WELL: before welding the end of the sliding bar on to the top of the square-holed ferrule, rotate the shaft of 5° at least.

Hole to take the retaining pin fastening the ferrule

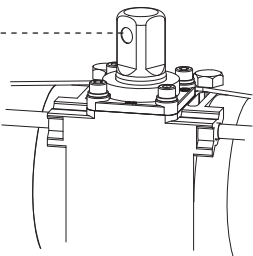

Bar sliding in the direction of the wall fixing

Stop plate in closed position (optional), to provide the door with a secure stop on closing

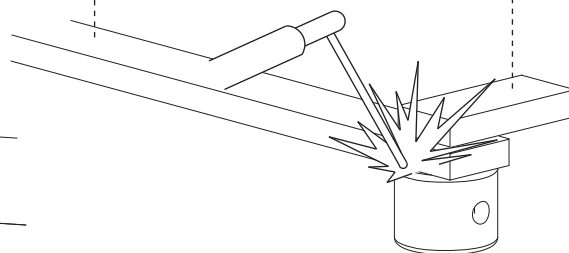

NOTE WELL: protect Aproli 380 LB while welding.

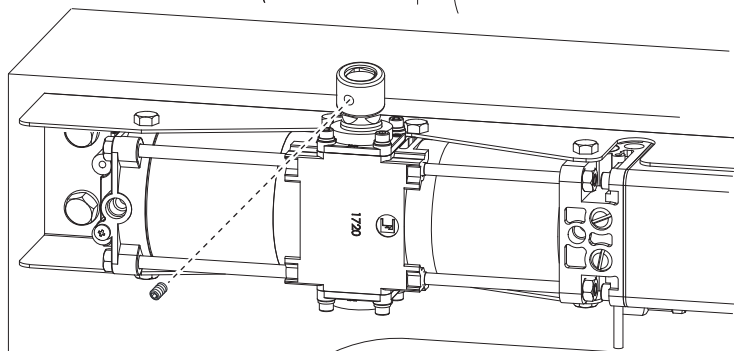

Pic. 11

ADJUSTING THRUST POWER

Aproli 380 LB has two adjustment screws to set the maximum and minimum pressure values, in compliance with the door inertia requirements, one in opening (*red screw*) and one in closing (*green screw*) (Pic. 12).

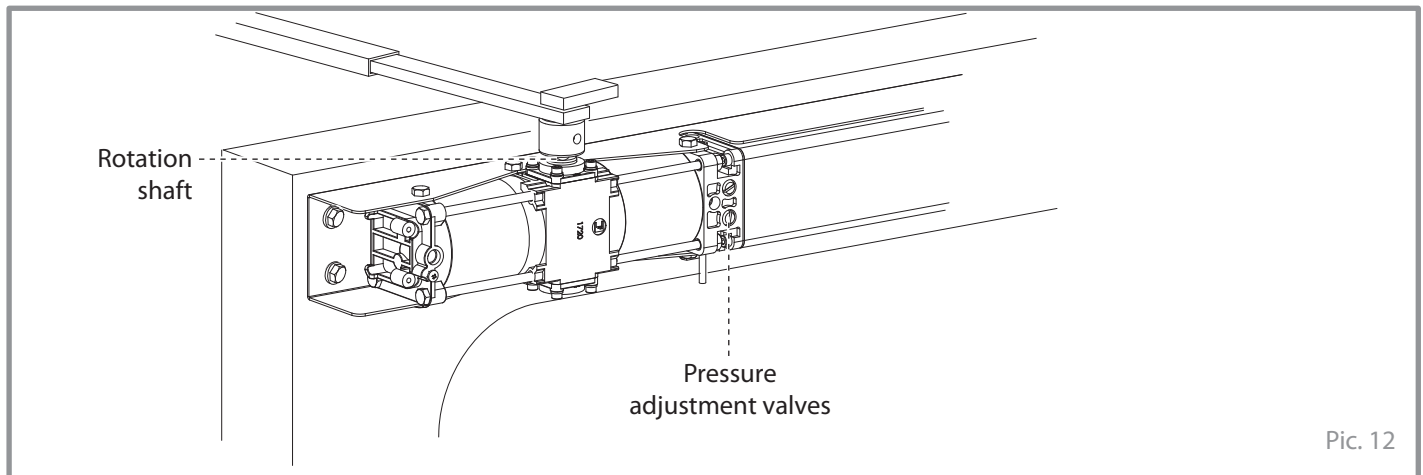

TECHNICAL SPECIFICATIONS

HYDRAULIC UNIT

P3 - Hydraulic pump capacity	0,85 l/min
Working pressure	10 atm
Maximum pressure	30 atm
Working temperature	-20 °C +80 °C [A]
Rated torque	196,2 Nm
Shaft rotation	max 205°
Oil type	Oil Fadini - Item 708L
Weight of operator	10,5 kg
Weight of Aproli 380 LB with accessories	16 kg
Max gate weight for double folding doors	250 kg
Protection standard	IP 67

[A]: -40 °C with specific optional accessories (Ref. General Catalogue).

PERFORMANCE

Frequency of use	intensive
Service cycle	opening ~ 23 s
	dwelling 15 s
	closing ~ 23 s
	dwelling 15 s
Complete cycle time	~ 76 s
Complete cycles opening-dwelling-closing-dwelling	No. 45/hour

ELECTRIC MOTOR

Power output	0,24 kW (0,33 HP)
Supply voltage	230 Vac
Frequency	50 Hz
Absorbed current	1,2 A
Absorbed power	250 W
Capacitor	12,5 µF
Motor rotation speed	1.350 rpm
Intermittent service	S3

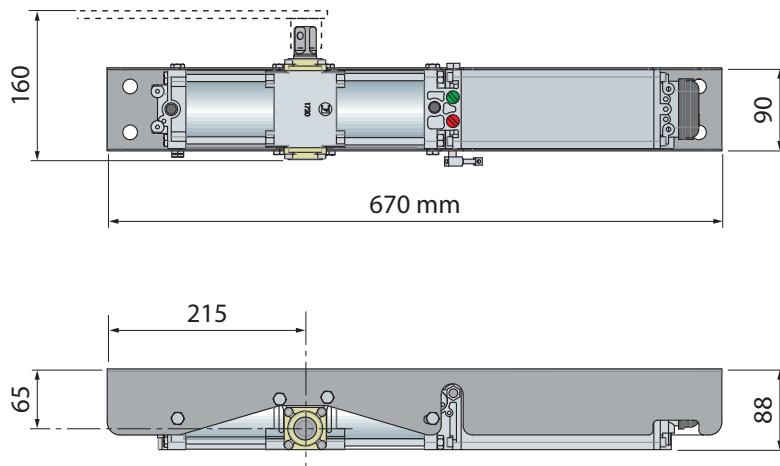

Pic. 13

hand over to the end user of the installation

English

MAINTENANCE RECORD hand over to the end user of the installation				
Installation address:	Maintainer:	Date:		
Installation type: Sliding gate <input type="checkbox"/> Folding door <input checked="" type="checkbox"/> Swinging gate <input type="checkbox"/> Road barrier <input type="checkbox"/> Over-head door <input type="checkbox"/> Bollard <input type="checkbox"/> Lateral folding door <input type="checkbox"/> <input type="checkbox"/>	Operator model:	Quantity of models installed:		
		Dimensions per gate leaf:		
		Weight per gate leaf:	Installation date:	
<p>NOTE WELL: this document must record any ordinary and extraordinary services including installation, maintenance, repairs and replacements to be made only by using Fadini original spare parts. This document, for the data included in it, must be made available to authorized inspectors/officers, and a copy of it must be handed over the end user/s.</p> <p>The installer/maintainer are liable for the functionalities and safety features of the installation only if maintenance is carried on by qualified technical people appointed by themselves and agreed upon with the end user/s.</p>				
N°	Service date	Service description	Technical maintainer	End user/s
1				
2				
3				
4				
5				
6				
_____ Stamp and signature installation technician/maintainer		_____ Signed for acceptance end user buyer		



GUIDANCE FOR PROPER USE (for the end user)**WARNINGS**

- Transit across the gate is allowed only if motor is stopped; stand at safe distance during opening and/or closing cycles of the gate.
- Do not touch any components of the system while the operator is working.
- Do not allow children and/or people to stand in the proximity of a working operator.
- Keep all the accessories able to turn on the operator (transmitters, proximity readers, key-switches, etc.) out of the reach of the children.
- Do not run the system in case of anomalies.

DISPOSAL OF MATERIAL: dispose properly of the packaging materials such as cardboard, nylon, polystyrene etc. through specializing companies (after verification of the regulations in force at the place of installation in the field of waste disposal). Disposal of electrical and electronic materials: to remove and dispose through specializing companies, as per Directive 2012/19/UE. Disposal of substances hazardous for the environment is prohibited.

MAINTENANCE

For optimum performance of system over time according to safety regulations, it is necessary to perform proper maintenance and monitoring of the entire installation: the automation, the electronic equipment and the cables connected to these. The entire installation must be carried out by qualified technical personnel. Operator: maintenance inspection at least every 6 months, while for the electronic equipment and safety systems an inspection at least once every month is required. The manufacturer, Meccanica Fadini S.r.l., is not responsible for non-observance of good installation practice and incorrect maintenance of the installation.

Advice for the end user:

- clear the site of materials that may have deposited in the equipment and hinder its correct functioning (such as rests of insects, foliage, stones, etc.); before carrying out this operation, switch off voltage supply;
- clean regularly the equipment by using a damp cloth. Do not use flammable substances such as alcohol, solvents or benzene: these substances may cause explosions and/or damage the system.

RELEASING FOR MANUAL OPERATIONS

The operator can be released for manual operations by a lever positioned under the bottom side (Pic. 14).

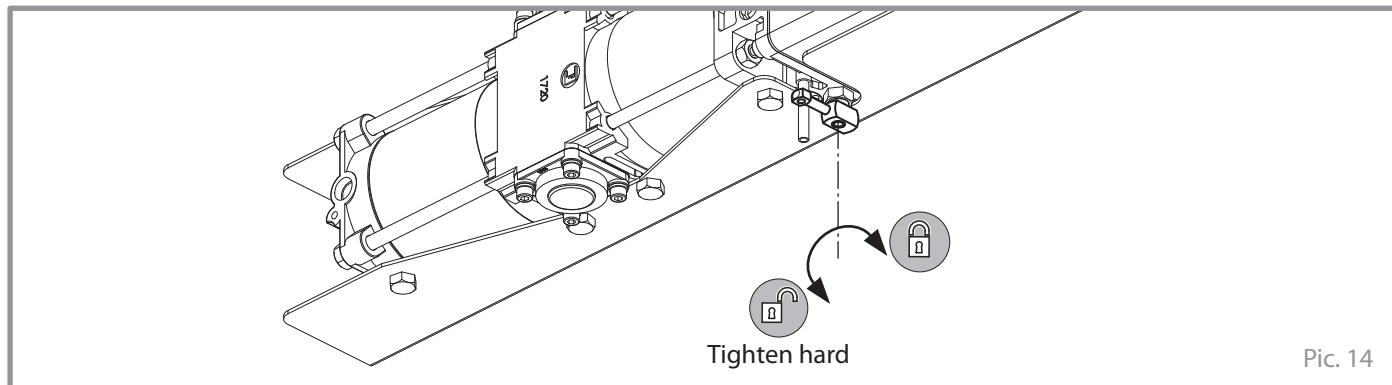

Pic. 14