

# Junior 624

## 24 Vdc

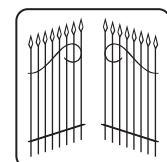

EN 13241  
EN 12453  
EN 12445



**FADINI**  
the gate opener  
Made in Italy

## GENERAL WARNINGS FOR PEOPLE SAFETY

### INTRODUCTION

This operator is designed for a specific scope of applications as indicated in this manual, including safety, control and signaling accessories as minimum required with **FADINI** equipment. □ Any applications not explicitly included in this manual may cause operation problems or damages to properties and people. □ Meccanica Fadini snc is not liable for damages caused by the incorrect use of the equipment, or for applications not included in this manual or for malfunctioning resulting from the use of materials or accessories not recommended by the manufacturer. □ The manufacturer reserves the right to make changes to its products without prior notice. □ All that is not explicitly indicated in this manual is to be considered not allowed.

### BEFORE INSTALLATION

Before commencing operator installation assess the suitability of the access, its general condition and the structure. □ Make sure that there is no risk of impact, crushing, shearing, conveying, cutting, entangling and lifting situations, which may prejudice people safety. □ Do not install near any source of heat and avoid contacts with flammable substances. □ Keep all the accessories able to turn on the operator (transmitters, proximity readers, key-switches, etc) out of the reach of the children. □ Transit through the access only with stationary operator. □ Do not allow children and/or people to stand in the proximity of a working operator. □ To ensure safety in the whole movement area of a gate it is advisable to install photocells, sensitive edges, magnetic loops and detectors. □ Use yellow-black strips or proper signals to identify dangerous spots. □ Before cleaning and maintenance operations, disconnect the appliance from the mains by switching off the master switch. □ If removing the actuator, do not cut the electric wires, but disconnect them from the terminal box by loosening the screws inside the junction box.

### INSTALLATION

All installation operations must be performed by a qualified technician, in observance of the Machinery Directive 2006/42/CE and safety regulations EN 12453 - EN 12445. □ Verify the presence of a thermal-magnetic circuit breaker 0,03 A - 230 V - 50 Hz upstream the installation. □ Use appropriate objects to test the correct functionality of the safety accessories, such as photocells, sensitive edges, etc. □ Carry out a risk analysis by means of appropriate instruments measuring the crushing and impact force of the main opening and closing edge in compliance with EN 12445. □ Identify the appropriate solution necessary to eliminate and reduce such risks. □ In case where the gate to automate is equipped with a pedestrian entrance, it is appropriate to prepare the system in such a way to prohibit the operation of the engine when the pedestrian entrance is used. □ Apply safety nameplates with CE marking on the gate warning about the presence of an automated installation. □ The installer must inform and instruct the end user about the proper use of the system by releasing him a technical dossier, including: layout and components of the installation, risk analysis, verification of safety accessories, verification of impact forces and reporting of residual risks.

### INFORMATION FOR END-USERS

The end-user is required to read carefully and to receive information concerning only the operation of the installation so that he becomes himself responsible for the correct use of it. □ The end-user shall establish a written maintenance contract with the installer/maintenance technician (on -call). □ Any maintenance operation must be done by qualified technicians. □ Keep this instruction carefully.

### WARNINGS FOR THE CORRECT OPERATION OF THE INSTALLATION

For optimum performance of system over time according to safety regulations, it is necessary to perform proper maintenance and monitoring of the entire installation: the automation, the electronic equipment and the cables connected to these. □

The entire installation must be carried out by qualified technical personnel, filling in the Maintenance Manual indicated in the Safety Regulation Book (to be requested or downloaded from the site [www.fadini.net/supporto/downloads](http://www.fadini.net/supporto/downloads)). □ Operator: maintenance inspection at least every 6 months, while for the electronic equipment and safety systems an inspection at least once every month is required. □ The manufacturer, Meccanica Fadini snc, is not responsible for non-observance of good installation practice and incorrect maintenance of the installation.

### DISPOSAL OF MATERIAL

Dispose properly of the packaging materials such as cardboard, nylon, polystyrene etc. through specializing companies (after verification of the regulations in force at the place of installation in the field of waste disposal). Disposal of electrical and electronic materials: to remove and dispose through specializing companies, as per Directive 2012/19/UE. Disposal of substances hazardous for the environment is prohibited.



# DECLARATION OF CONFORMITY

## of the Manufacturer

Manufacturing company:



**meccanica FADINI** s.n.c.

Via Mantova, 177/A - 37053 Cerea (VR) Italy  
Tel.+39 0442 330422 r.a. - Fax +39 0442 331054  
e-mail: info@fadini.net - www.fadini.net

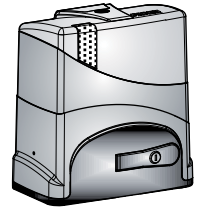

**DECLARES UNDER ITS OWN RESPONSIBILITY THAT:**

Electro-mechanical operator for sliding gates

# Junior 624

IS IN COMPLIANCE WITH THE NORMS.....**2006/42/CE**  
and that:

ITT - PDC/0976-2010 - 30/04/2010

Junior 624 is to be sold and installed as a comprehensive "Automatic System", including the accessories and components as recommended by the Manufacturing Company.  
In observance of the current directives, any automation is to be regarded as a "machine". Therefore it is required that all the applicable safety norms are strictly complied with by installation agents, who are also required to issue a Declaration of Conformity.  
The manufacturing company is not liable for incorrect applications or misuse of its products that are declared to be produced in compliance with the following norms:

- Analysis of the risk and actions to cure them: ..... **EN 12445 & EN 12453**
- Low Voltage Directive..... **2014/35/UE**
- Electro-magnetic Compatibility Directive ..... **2014/30/UE**

In order to certify the product the Manufacturer declares under his own responsibility the compliance with the **PRODUCT regulations under the NORMS.....EN 13241-1**

Notified institute and laboratory for product according to DM 2004/108/CE:

**Istituto di Ricerche e Collaudi M.Masini srl - Via Moscova, 11 - 20017 Rho (MI)**

- CE 0068 - Notified
- SINCERT 047A Certified - SINAL 0019 Certified
- Conforming to the following Standards: UNI EN 1324-1, UNI EN 12604, UNI EN 12605, UNI EN 12445, UNI EN 12453

Meccanica FADINI s.n.c.



The Responsible Manager

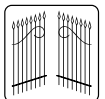

**FADINI**  
the gate opener  
Made in Italy

**GB** Date: 19-04-17

## MAIN COMPONENTS FOR INSTALLATION

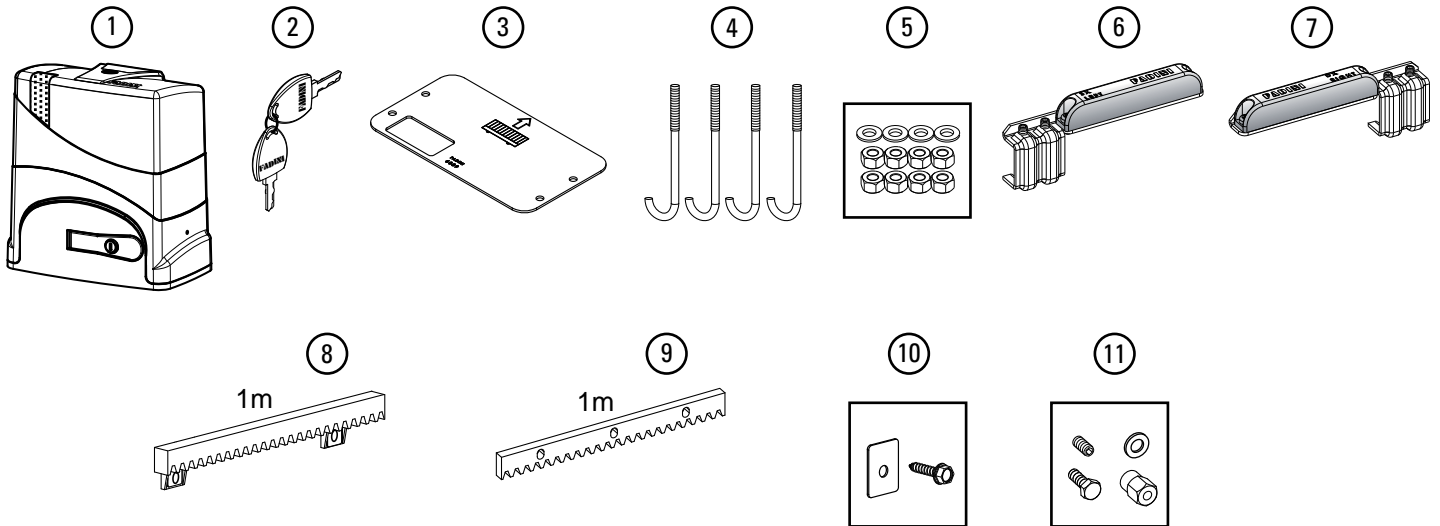

- 1 - Junior 624 series electro-mechanical operator for sliding gates complete with programmer Elpro 62
- 2 - n° 2 coded keys for manual unlocking
- 3 - Base plate
- 4 - n° 4 Anchor bolts
- 5 - n° 8 M10 hexagonal nuts+washers
- 6 - LH magnet bracket for limit switch
- 7 - RH magnet bracket for limit switch
- 8 - Nylon gear rack (not supplied in the kit)
- 9 - 30x8 steel gear rack (not supplied in the kit)
- 10 - n° 30 pcs. Self-threading screws with square washer for nylon gear rack (not supplied in the kit)
- 11 - n° 30 pcs. Washers and fixing bolts (not supplied in the kit) for steel gear rack

**Pic. 1**

**MAIN COMPONENT LIST**

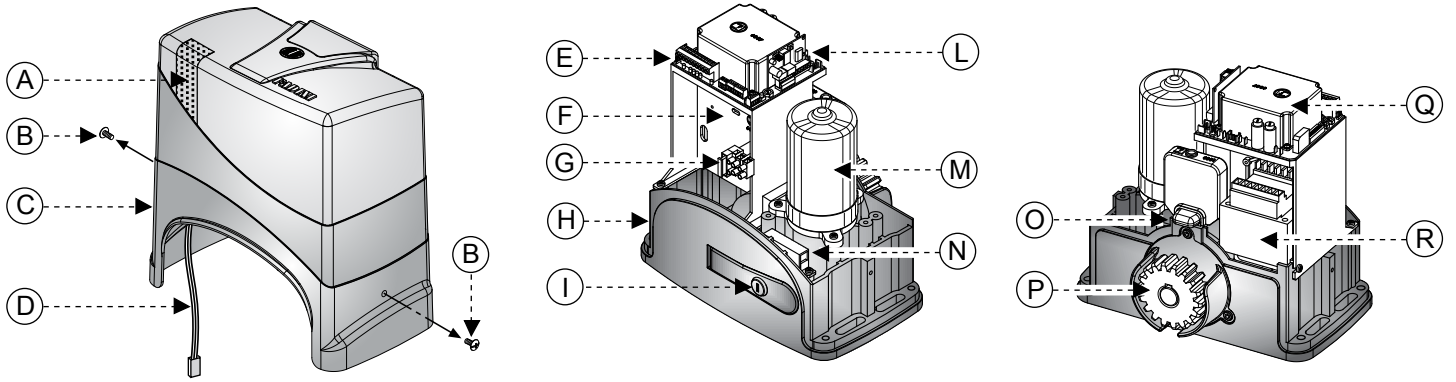

- A - Led light, blue and amber colours, for automation status indication
- B - Casing fixing screws
- C - Casing
- D - LED power supply cable
- E - Elpro 62 programmer for Junior 624
- F - Programmer support
- G - Line fuse with terminal block
- H - Gear box

- I - Manual unlock handle with coded key
- L - Plug-in radio receiver
- M - 24V DC electrical Motor
- N - Electrical power disconnection microswitch for the unlocking handle
- O - Magnetic limit switch
- P - M4 Z18 pinion
- Q - Programmer cover
- R - 230V-24V 150VA Transformer for Junior 624

**Pic. 2**

**SYSTEM ACCESSORIES AND ELECTRICAL CONNECTIONS**

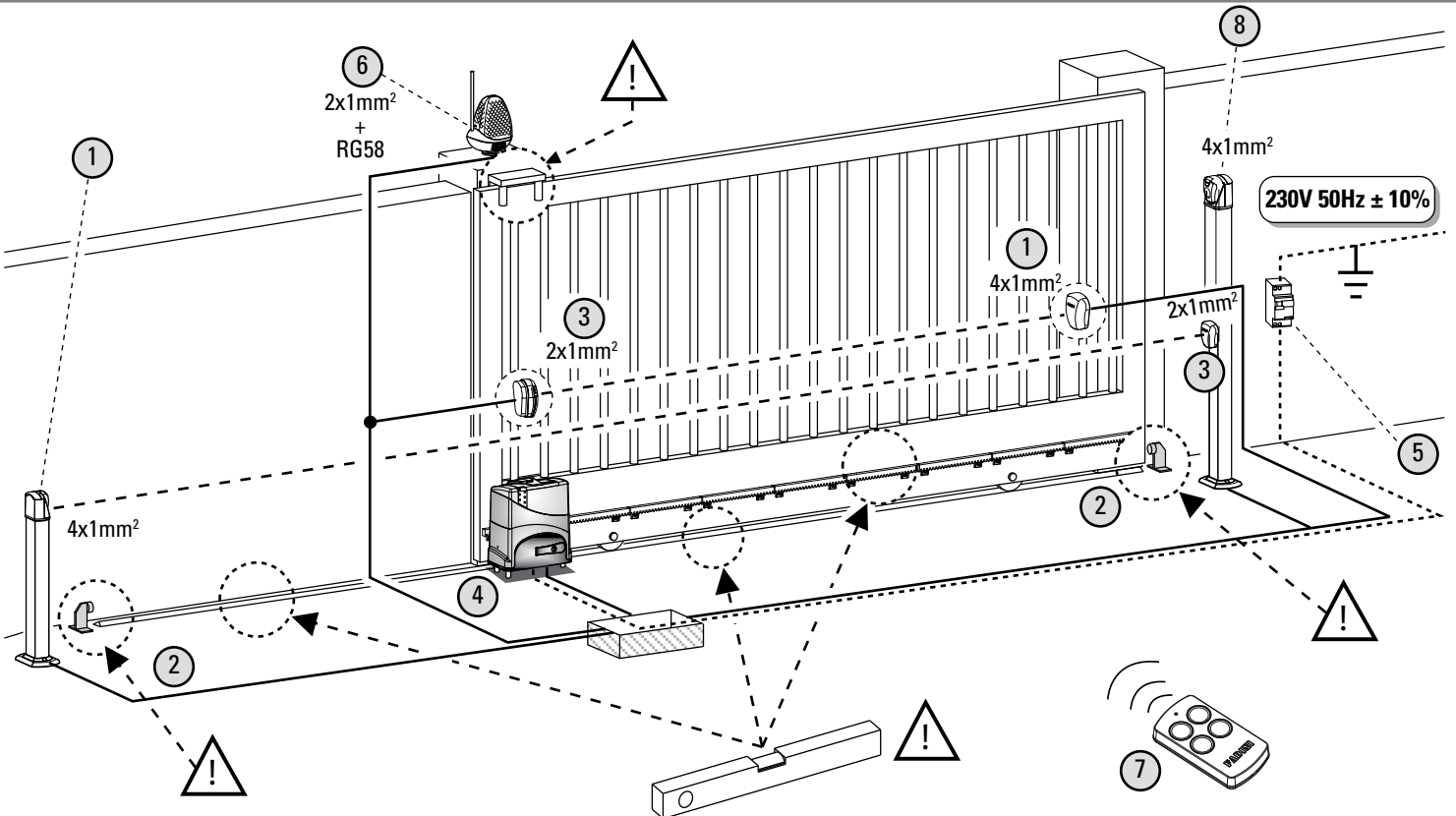

**!** = Attention: verify the integrity of the structure and the linearity of the gate movement, removing any noted friction or resistance.

- 1- Fit 55 photocell receiver
- 2- Gate end stop
- 3- Fit 55 photocell projector
- 4- Junior 624 with programmer Elpro 62 and Vix 53/2 R plug-in radio receiver
- 5- 230V - 50Hz magneto-thermal differential line circuit breaker, 0.03A
- 6- Miri 4 flasher with rod aerial
- 7- Vix 53/4 TR radio transmitter
- 8- Key-switch CHIS 37

**Pic. 3**

**CASING OPENING**



**ATTENTION:** once the two side screws have been removed, lift the casing and **vertically pull it out, without tearing** off the "led" card cable connector.

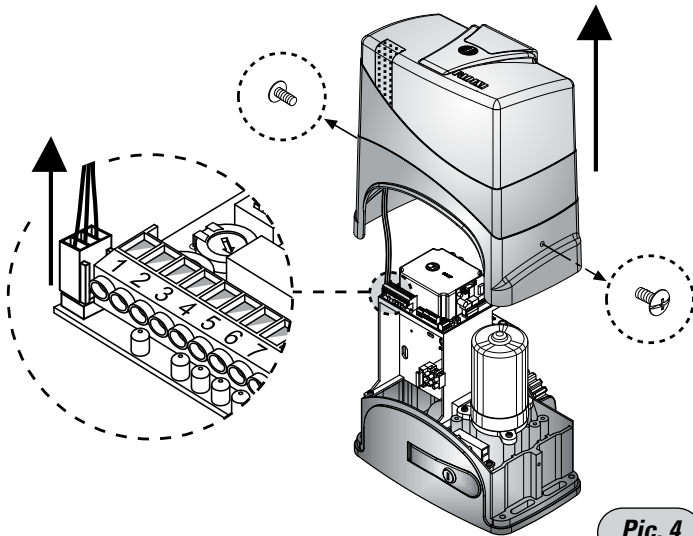

Pic. 4

**ANCHOR PLATE**



**ATTENTION:** the nut under the plate must be 47 mm from the top end of the bolt.

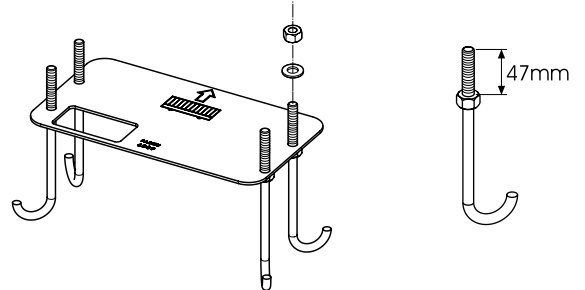

- n°1 Base plate
- n°4 Anchor bolts
- n°8 M10 hexagonal nuts + washers

Pic. 5

**ANCHORING WITH A BASE PLATE**

position and anchor the base plate at a distance of **60 mm** from the gate to be opened, levelling it flat

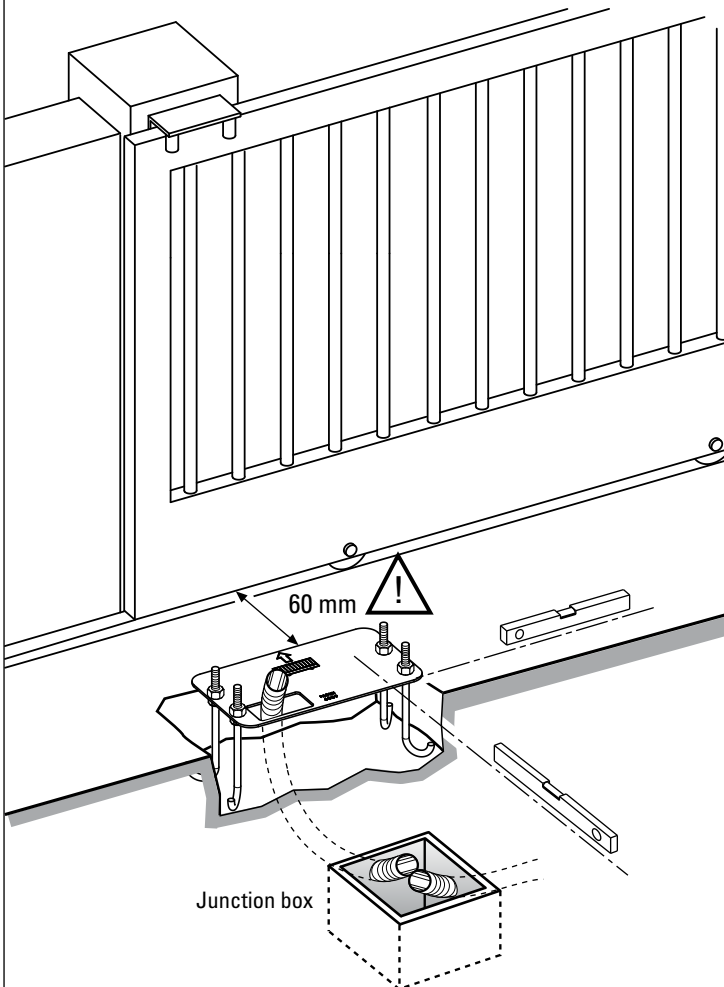

Pic. 6

**ANCHORING WITH PLUGS (not supplied)**

It is important that the threading should project **40 mm** from the ground

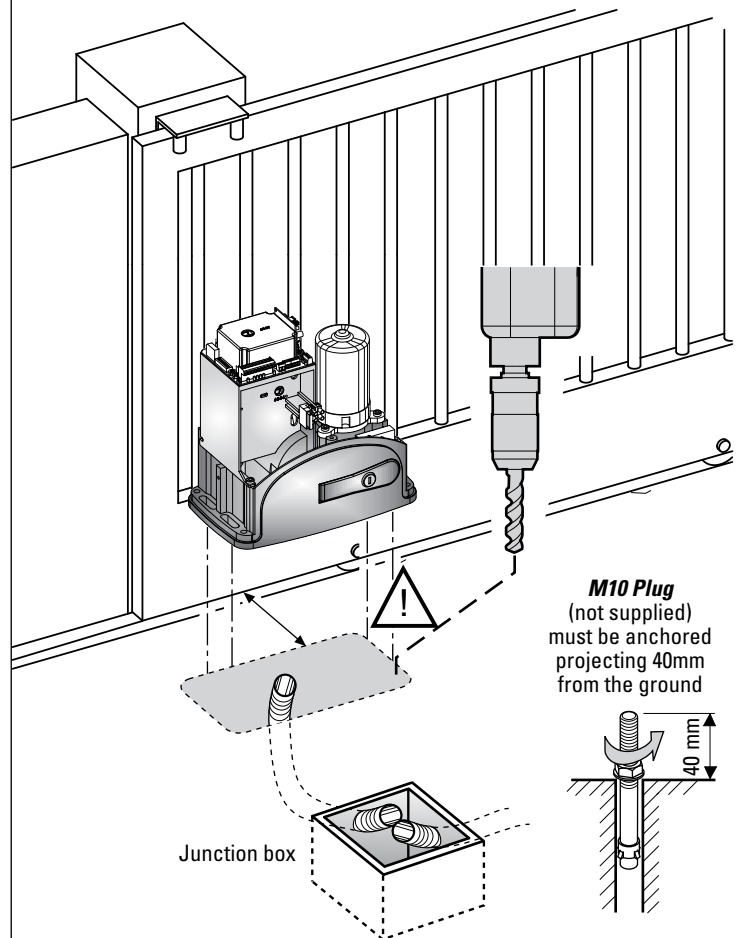

**M10 Plug**  
(not supplied)  
must be anchored  
projecting 40mm  
from the ground

Pic. 7

**ANCHORING THE JUNIOR**

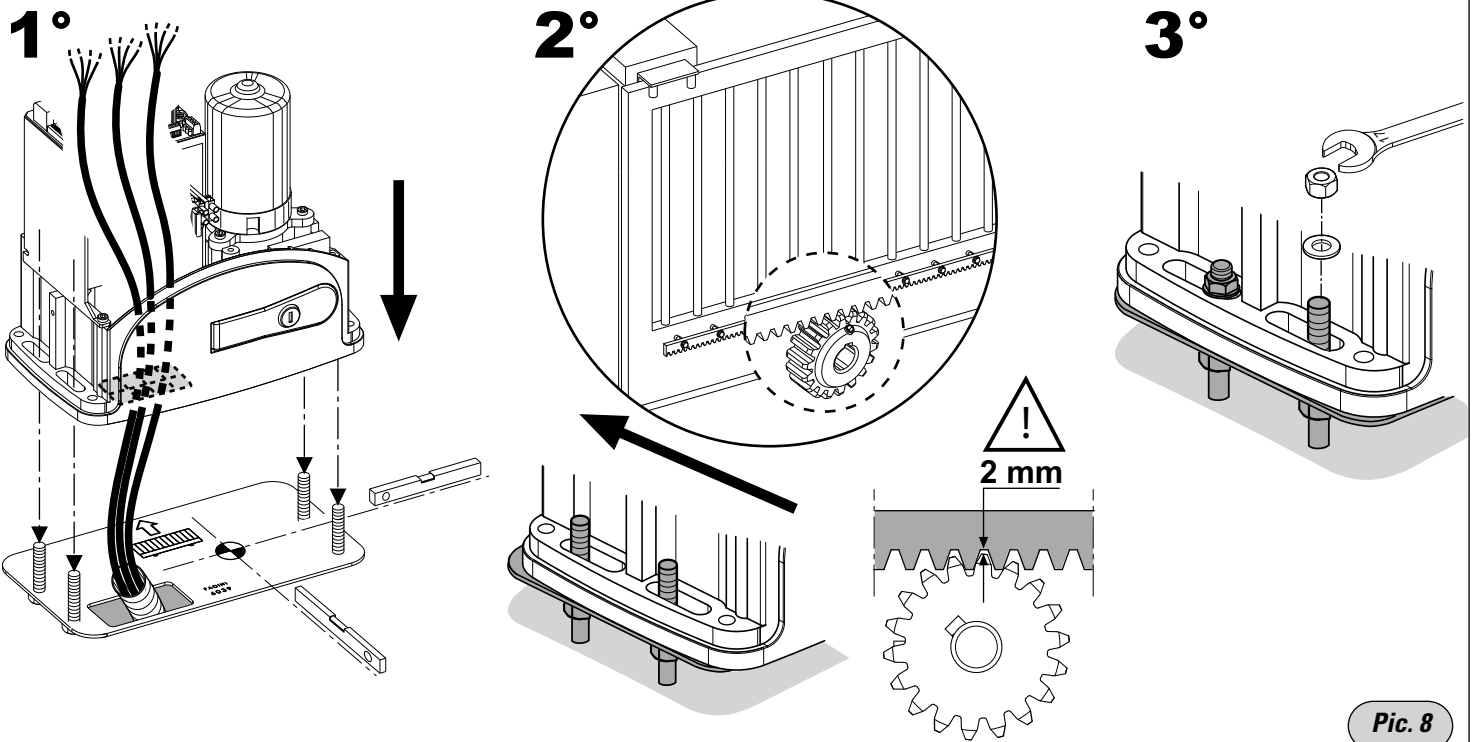

Pic. 8

**ELECTRICAL POWER SUPPLY TO THE PROGRAMMER**

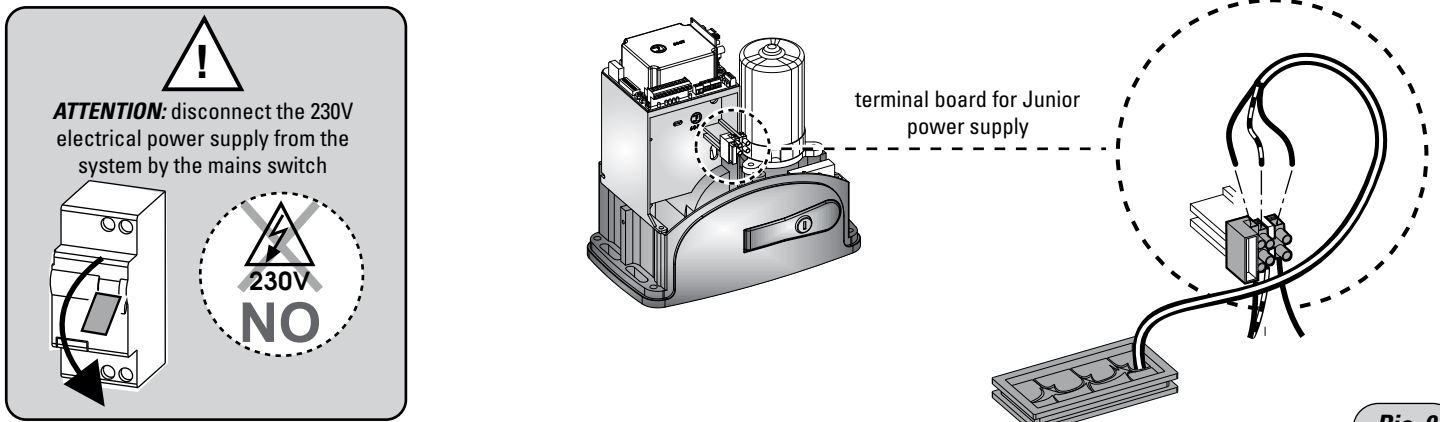

Pic. 9

**DISTINCTION OF JUNIOR INSTALLED ON THE RIGHT OR LEFT**

The first operation to be performed is to identify the Junior installation with respect to the opening of the gate, moving Dip-Switch n°11 on the Elpro 62 programmer (already installed on the Junior 624), depending on the position of Junior as seen inside the gate to be opened.

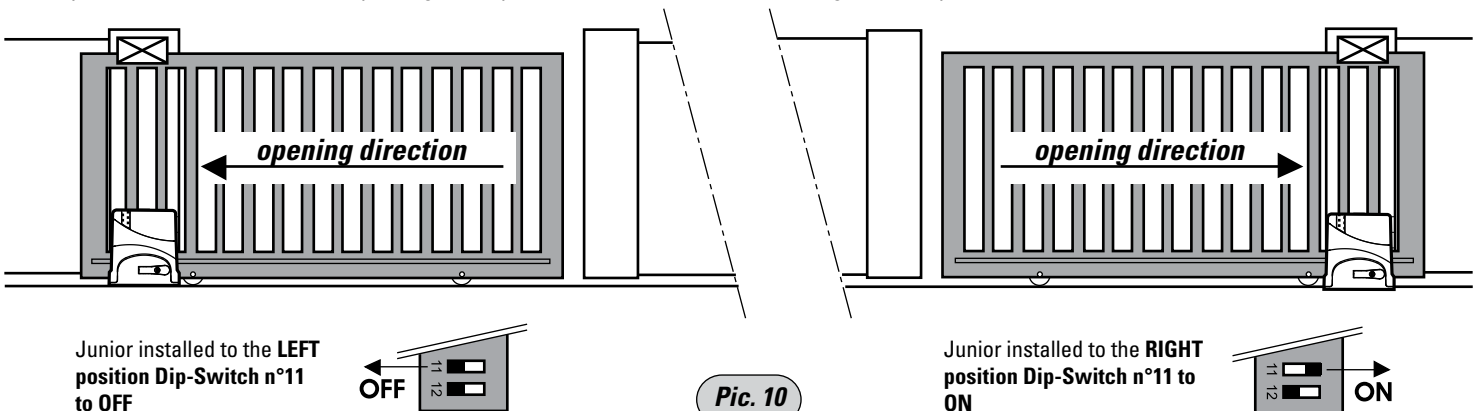

Pic. 10

**FASTENING THE LIMIT SWITCH BRACKETS TO THE GEAR RACK**



**ATTENTION:** do not open and invert the single magnets inside the limit switch plastic bracket. These have already been properly installed to be identified by programmer logic.

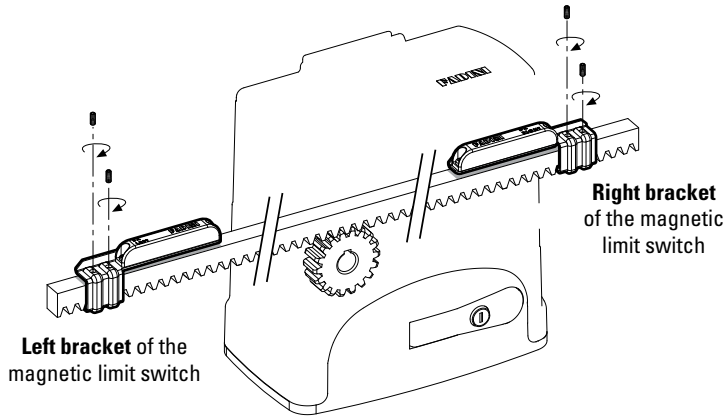
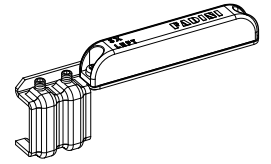

**NOTE WELL:** IT IS MOST IMPORTANT THAT THE GATE DOES NOT RUN INTO THE GATE STOPS IN OPENING AND CLOSING CYCLES. A 30-50 mm CLEARANCE IS RECOMMENDED ON LIMIT SWITCH ENGAGING, AS INDICATED.

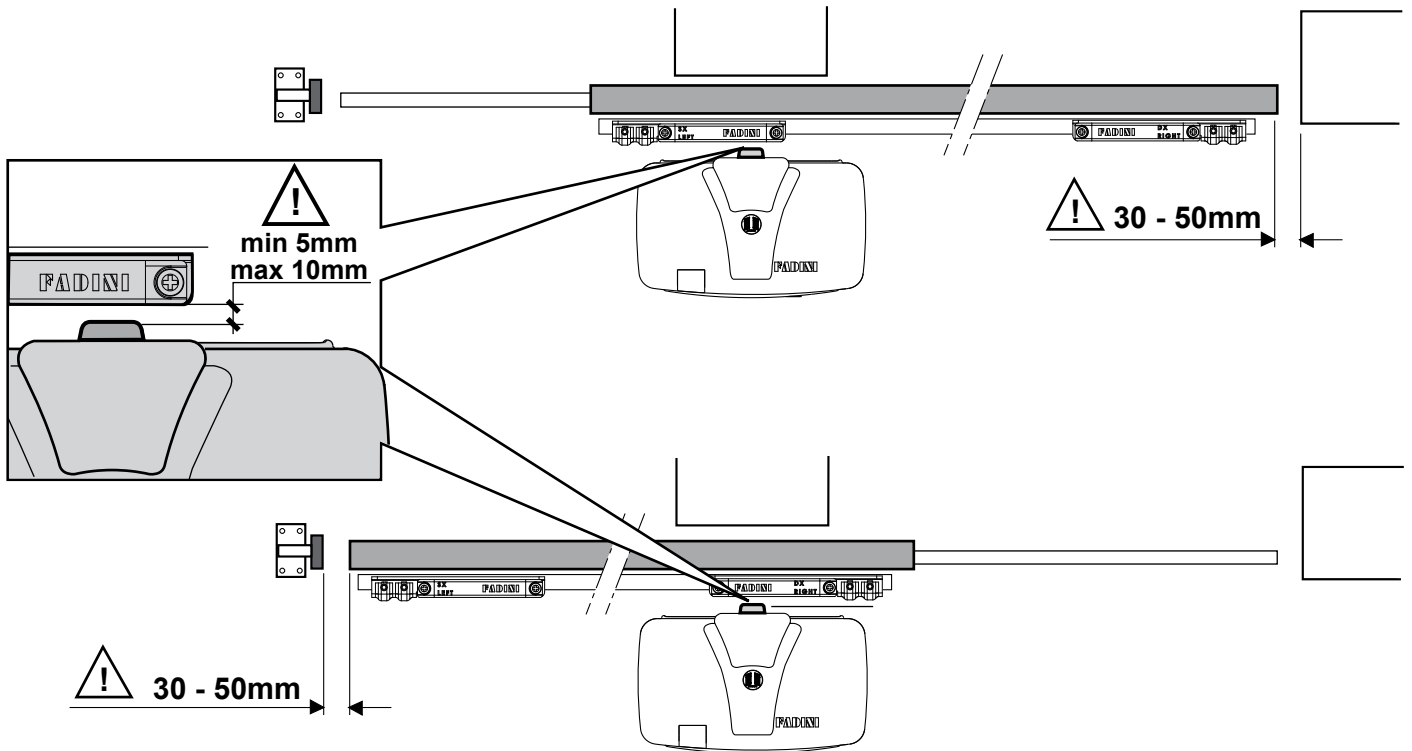

Pic. 11





**Junior 624**  
max 400 kg

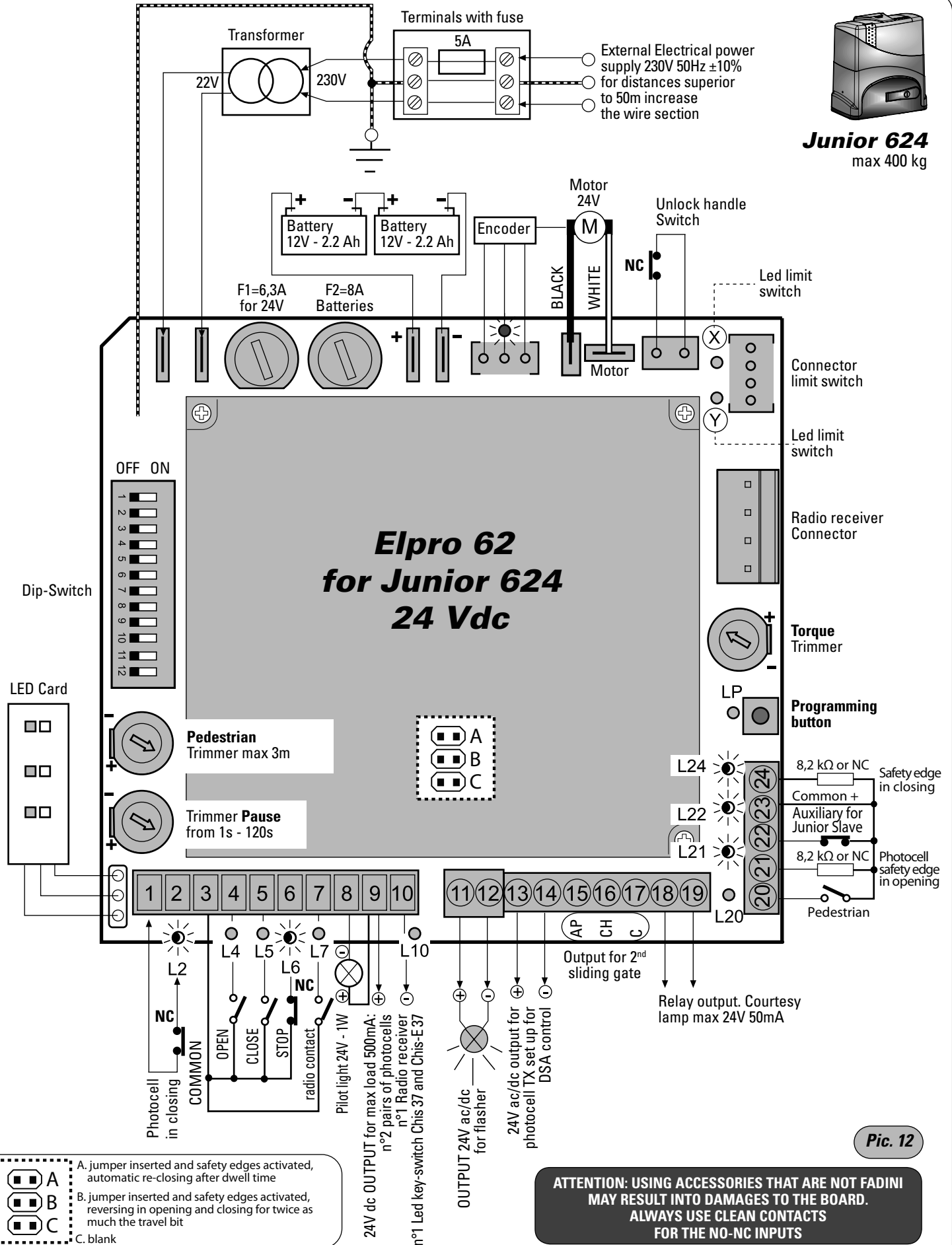

**Pic. 12**

- A.** jumper inserted and safety edges activated, automatic re-closing after dwell time
- B.** jumper inserted and safety edges activated, reversing in opening and closing for twice as much the travel bit
- C.** blank

**LED on** **P.N.** The LEDs shown here are in their normal status and correct functioning of **ELPRO 62** PCB.  
**LED off** **The green LEDs must always be on.**

**ATTENTION: USING ACCESSORIES THAT ARE NOT FADINI MAY RESULT INTO DAMAGES TO THE BOARD. ALWAYS USE CLEAN CONTACTS FOR THE NO-NC INPUTS**

**NOTE: all of the possible connections to the programmer terminal boards are also illustrated in the respective instructions sheets for each individual accessory.**



**ATTENTION !!** The installation of this product must be performed by professionally trained and qualified personnel according to the safety regulations in force. It is important to carefully read and follow the instructions so as to avoid incorrect use of this same product. The ELPRO 62 electronic programmer was conceived and manufactured for the management of the Junior 624 electromechanical sliding operator with 24 V DC motors. Any other use different from that specified in this instruction booklet is to be considered prohibited.



**ATTENTION !!** The Meccanica Fadini Company declines any responsibility for damages caused to properties and/or people due to any improper installation or the failure of bringing the system to compliance with the laws and regulations in force. The application of the Machine Directive 2006/42/CE is required. All of the maintenance and/or test operations of the status of the product must be performed by professionally trained and qualified personnel.

**ATTENTION !! Important:** before carrying out any procedure on the PCB card, disconnect the electrical power supply mains. It is furthermore recommended that the "Safety Regulations" made available by Meccanica Fadini be examined thoroughly.

**General description:** The Elpro 62 is a PCB card with microprocessor for the command and management of the Junior 624 sliding gate opener with programming for self-learning of the different movement phases of the gate.

**Power Supply:** 230V 50Hz±10% monophasic corresponding to the 2006/95/CE Low Voltage directive and the 2004/108/CE Electro-magnetic Compatibility Directive.

**Logic Operation:** given the open command impulse, it performs the function for open, pause, close in automatic or semi-automatic with programmable slowdown, possibility of step by step radio command, radio no reverse on opening, with or without pre-flashing, exclusion of closing slow down, reverse run upon contact with an obstacle and LED diagnostics. Rh and Lh installations are made selectable by Dip-switch, Blue/Amber LED diffuser on the cover casing for the gate opener status signal.

**DIAGNOSTIC LED:** LED status during proper operation of the system, the green LEDs must always be on; the red LEDs must always be off.

- L2 (green on)** = Photocells, turns off with obstacle present
- L4 (red off)** = Open, lights up with the opening command impulse
- L5 (red off)** = Close, lights up with the closing command impulse
- L6 (green on)** = Stop, goes off with the stop command impulse
- L7 (red off)** = Radio, lights up with each transmitter impulse
- L10 (red off)** = Lights up in case of short circuit with 24 Vdc. It goes off when circuit problem is corrected
- L20 (red off)** = Pedestrian, lights up with the open for pedestrian switch
- L21 (green on)** = Photocell or safety edge in open, turns off in case of obstacle
- L22 (green on)** = Enter of 2<sup>nd</sup> Junior
- L24 (green on)** = Safety edge in closing, turns off in case of obstacle
- LP (red off)** = Program led, it lights on in phase of programming
- X (rosso)** = led limit switch, always alight during the movement
- Y (rosso)** = led limit switch, always alight during the movement

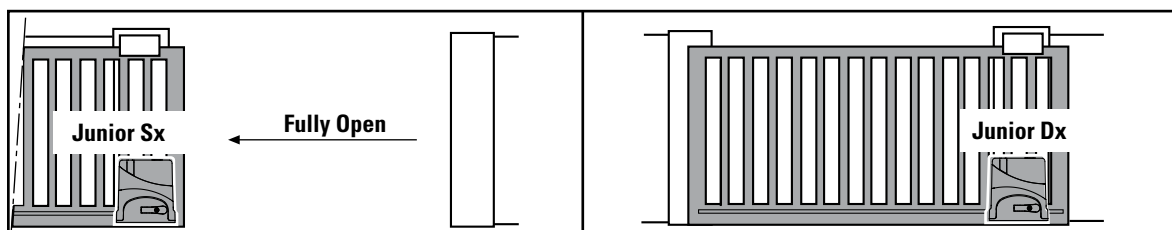
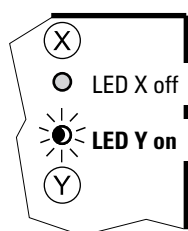
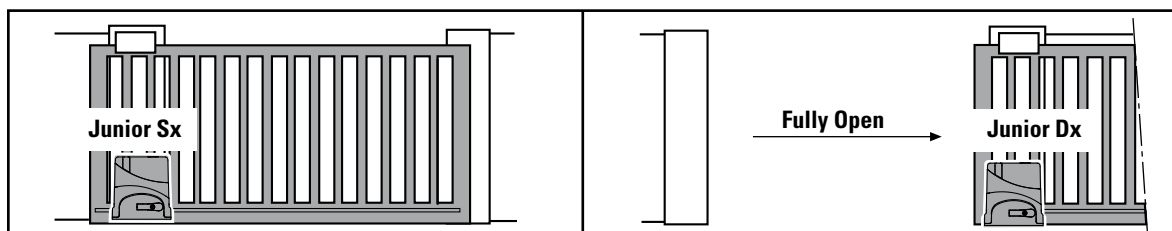
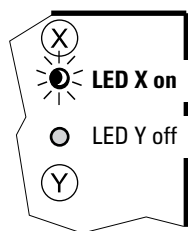
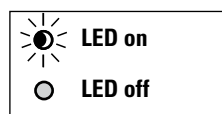





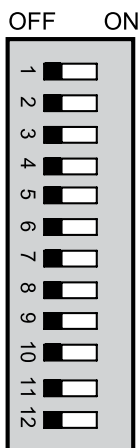

**DIP-SWITCHES:** enable the performance of all of the possible functions of the Junior 624 sliding gate opener

- 1 = OFF:** Photocell does not stop gate in opening
- 2 = OFF:** Radio stops and reverses in opening
- 3 = OFF:** Semiautomatic operation
- 4 = OFF:** Without pre-flashing before opening
- 5 = OFF:** Radio reverses direction on every impulse
- 6 = OFF:** Slowdowns (to be programmed)
- 7 = OFF:** Blank
- 8 = OFF:** Flasher on in pause
- 9 = OFF:** No closing after passage by the photocell
- 10 = OFF:** No DSA control on the photocells
- 11 = OFF:** Junior 624 installed on the Left
- 12 = OFF:** Single Elpro 62, or 1<sup>st</sup> Junior 624 as MASTER

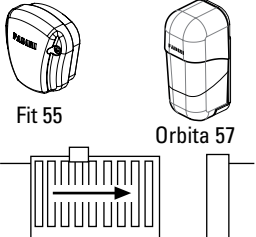
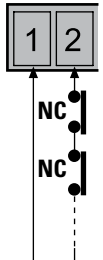

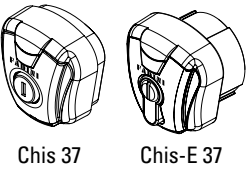
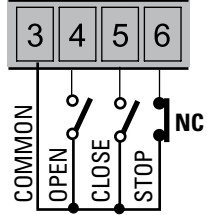

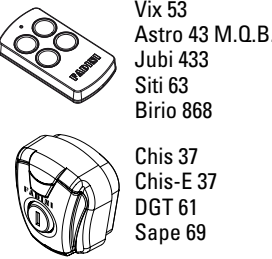
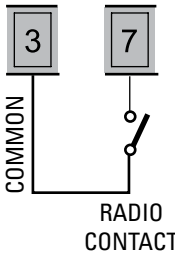
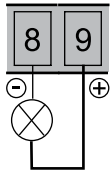
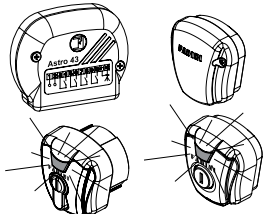
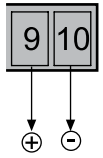

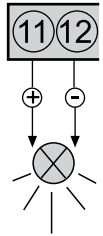
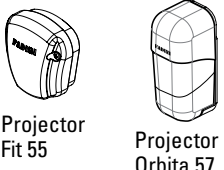
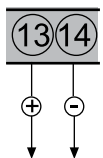

- 1 = ON:** Photocell stops gate in opening
- 2 = ON:** Radio does not reverse (and does not stop) in opening
- 3 = ON:** Close in automatic after pause time
- 4 = ON:** Pre-flashing before opening
- 5 = ON:** Radio switch: open-stop-close-stop
- 6 = ON:** Slowdowns out of service
- 7 = ON:** Blank
- 8 = ON:** Flasher off in pause
- 9 = ON:** Closing after passage by the photocell
- 10 = ON:** DSA Photocell control before start up
- 11 = ON:** Junior 624 installed on the Right
- 12 = ON:** Elpro 62 SLAVE with 2<sup>nd</sup> Junior 624

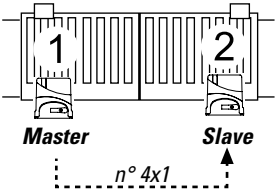
**ELECTRICAL CONNECTIONS TO THE TERMINALS AND THEIR FUNCTIONS**

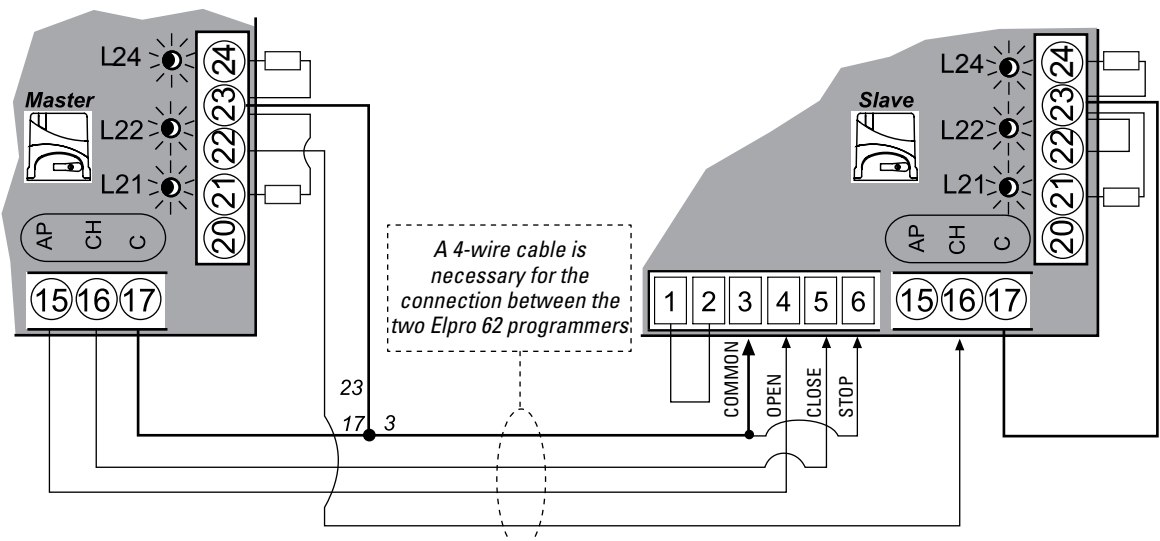
Accessory	Electrical connections	Dip-Switch and LED indication of their functions
<p><b>Photocells in closing:</b></p> 	 <p>All of the <b>NC contacts</b> on the Photocells in <b>closing phase</b> must be connected in series to the terminals 1 and 2.</p>	<p><b>DIP-SWITCH 1</b></p> <ul style="list-style-type: none"> <li><input checked="" type="checkbox"/> <b>ON:</b> stops gate on opening and reverses it on closing once obstacle is removed</li> <li><input type="checkbox"/> <b>OFF:</b> no stop on opening, gate is reversed on closing in case of an obstacle</li> </ul>  <b>L2 green On</b> = no obstacle, it turns off in case of obstacle
<p><b>Key-switch:</b></p> 	 <p>NO and NC contacts to be connected to the respective terminals of the key- or button-switches. All the possible configurations are attached to their respective command accessories.</p>	<ul style="list-style-type: none"> <li><input type="checkbox"/> <b>L4 red Off</b>= no contact OPEN, it lights up with each opening impulse</li> <li><input type="checkbox"/> <b>L5 red Off</b>= no contact CLOSE, it lights up with each closing impulse</li> <li> <b>L6 green On</b>= STOP contact closed, it turns off at each stop contact</li> </ul>
<p><b>Radio contact:</b></p> 	 <p>By connecting any NO contact between the two terminals, each impulse can perform:</p> <ul style="list-style-type: none"> <li>- Only opening: <b>Dip 2=ON and Dip 5=OFF</b></li> <li>- Reverse direction on each impulse <b>Dip 2=OFF and Dip 5=OFF</b></li> <li>- Step by Step: Open-Stop-Close-Stop <b>Dip 2=OFF and Dip 5=ON</b></li> </ul>	<p><b>DIP-SWITCH 2 and 5 (MUST NOT ever be simultaneously ON)</b></p> <ul style="list-style-type: none"> <li><input checked="" type="checkbox"/> <b>ON:</b> Does not reverse and does not stop in opening</li> <li><input type="checkbox"/> <b>OFF:</b> In opening always stops and reverses</li> </ul> <ul style="list-style-type: none"> <li><input checked="" type="checkbox"/> <b>ON:</b> Step by step with intermediate stop</li> <li><input type="checkbox"/> <b>OFF:</b> Reverses direction on every impulse</li> </ul> <ul style="list-style-type: none"> <li><input type="checkbox"/> <b>L7 red Off</b> = no RADIO contact, it lights on at every impulse of radio contact</li> </ul>
<p><b>Warning Lamp Output 24V- 1W:</b></p>	 <p>Output for a possible automation status warning lamp:  Warning Lamp <b>On</b> = Gate Open  Warning Lamp <b>Off</b> = Gate Closed  Flashing at <b>0,5s (fast)</b>= closing movement  Flashing at <b>1s (normally)</b>= opening movement</p>	
<p><b>24V Output:</b></p> 	 <p>24V dc OUTPUT for max load:  n° 2 pairs of photocells  n° 1 Radio receiver  n° 1 Led key-switch Chis 37/Chis-E 37  All the instructions are attached to their respective command accessories</p>	
<p><b>24 Volt flashing lamp:</b></p> 	 <p>24 Volt dc OUTPUT for flasher</p>	<p><b>DIP-SWITCH 4 and 8</b></p> <ul style="list-style-type: none"> <li><input checked="" type="checkbox"/> <b>ON:</b> Pre-flashing before opening</li> <li><input type="checkbox"/> <b>OFF:</b> without pre-flashing</li> </ul> <ul style="list-style-type: none"> <li><input checked="" type="checkbox"/> <b>ON:</b> Flasher deactivated during pause in automatic operation (with <b>Dip 3= ON</b>)</li> <li><input type="checkbox"/> <b>OFF:</b>Flashes during pause in automatic Operation (with <b>Dip 3= ON</b>)</li> </ul>
<p><b>Output 24V ac/dc for DSA control:</b></p> 	 <p>24V Output to power the photocell transmitters (connected in parallel) for the <b>DSA control: Autotest Safety Device</b>=  If activated, before opening or closing movements all the security devices are checked for faults. In case any malfunction is detected, the operator is prevented from starting and the LED on the Junior cover keeps flashing with alternated Blue and Orange lights.</p>	<p><b>DIP-SWITCH 10</b></p> <ul style="list-style-type: none"> <li><input checked="" type="checkbox"/> <b>ON:</b> DSA control of the photocells. The photocell projectors, outputs 13-14, must be powered</li> <li><input type="checkbox"/> <b>OFF:</b> No DSA control of the photocells</li> </ul>

**ELECTRICAL CONNECTIONS TO THE TERMINAL BOARDS AND THEIR FUNCTIONS**

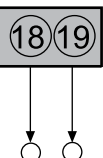
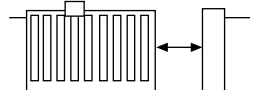
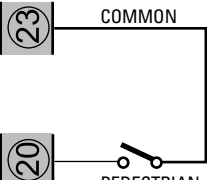
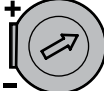
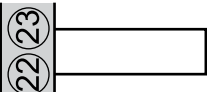
Accessory	Electrical connections	Dip - Switch and LED indication of their functions		
<p><b>Connections for n°2 Junior 624 sliding gate operators</b></p> 	<div style="border: 1px solid black; padding: 5px; margin-bottom: 10px;">  <p>It is important to determine which Elpro 62 MASTER will command and control the Elpro 62 SLAVE. All the accessories for command, signalling and safety must be connected to the terminals of the Elpro 62 MASTER that manages and controls the entire system. If the gates aren't of the same length, the Elpro 62 Master is to be mounted on the longest one.</p> </div> <p>Carry out the following connections:</p> <table border="0" style="width: 100%;"> <tr> <td style="width: 50%; vertical-align: top;"> <p><b>Elpro 62 MASTER</b> Dip-Switch 12=OFF:</p> <p>terminal 15 (open) -----&gt;</p> <p>terminal 16 (close) -----&gt;</p> <p>terminal 17-23 (common) -----&gt;</p> <p>terminal 22 -----&gt;</p> </td> <td style="width: 50%; vertical-align: top;"> <p><b>Elpro 62 SLAVE</b> Dip-Switch 12=ON:</p> <p>terminal 4 (open) -----&gt;</p> <p>terminal 5 (close) -----&gt;</p> <p>terminal 3 (common) -----&gt;</p> <p>terminal 16 (close)</p> <p>terminal 17 jumper with 23</p> <p>terminal 1 jumper with 2</p> <p>terminal 3 (common) jumper with 6 (stop)</p> </td> </tr> </table>  <div style="border: 1px solid black; padding: 5px; margin-top: 10px; text-align: center;">  <p><b>PROGRAMME JUNIOR MASTER AND SLAVE SEPARATELY ONCE THE ELECTRICAL CONNECTIONS HAVE BEEN MADE AND THE DIP-SWITCHES SET CORRECTLY</b></p> </div>	<p><b>Elpro 62 MASTER</b> Dip-Switch 12=OFF:</p> <p>terminal 15 (open) -----&gt;</p> <p>terminal 16 (close) -----&gt;</p> <p>terminal 17-23 (common) -----&gt;</p> <p>terminal 22 -----&gt;</p>	<p><b>Elpro 62 SLAVE</b> Dip-Switch 12=ON:</p> <p>terminal 4 (open) -----&gt;</p> <p>terminal 5 (close) -----&gt;</p> <p>terminal 3 (common) -----&gt;</p> <p>terminal 16 (close)</p> <p>terminal 17 jumper with 23</p> <p>terminal 1 jumper with 2</p> <p>terminal 3 (common) jumper with 6 (stop)</p>	<p><b>DIP-SWITCH 12</b></p> <div style="border: 1px solid black; padding: 5px; margin-bottom: 10px;"> <p><input checked="" type="checkbox"/> <b>ON:</b> Elpro 62 SLAVE (2<sup>nd</sup> Junior 624)</p> <p><input type="checkbox"/> <b>OFF:</b> Elpro 62 MASTER (1<sup>st</sup> Junior 624)</p> </div> <div style="border: 1px solid black; padding: 5px;">  <p>Refer to the previous pages for the Dip-switch arrangements relative to the individual accessories and functions.</p> </div> <p> <b>L21, L22 and L24 green ON</b> of both programmers to confirm proper communication between the two Elpro 62</p>
<p><b>Elpro 62 MASTER</b> Dip-Switch 12=OFF:</p> <p>terminal 15 (open) -----&gt;</p> <p>terminal 16 (close) -----&gt;</p> <p>terminal 17-23 (common) -----&gt;</p> <p>terminal 22 -----&gt;</p>	<p><b>Elpro 62 SLAVE</b> Dip-Switch 12=ON:</p> <p>terminal 4 (open) -----&gt;</p> <p>terminal 5 (close) -----&gt;</p> <p>terminal 3 (common) -----&gt;</p> <p>terminal 16 (close)</p> <p>terminal 17 jumper with 23</p> <p>terminal 1 jumper with 2</p> <p>terminal 3 (common) jumper with 6 (stop)</p>			
<p><b>Relay output for courtesy lamp, 24V 50mA</b></p>	 <p>Relay output for courtesy lamp max 24V 50mA</p>			
<p><b>Pedestrian opening</b></p> 	 <p>NO input for external contact for pedestrian opening</p>	 <p><b>Pedestrian Trimmer:</b> the opening distance of the gate is adjusted up to 3 metres. In Automatic function (Dip 3=ON, closes after pause time completed)</p>		
<p><b>NC contact for 2<sup>nd</sup> Junior</b></p>	 <p>Factory-fitted Jumper. NC contact for connection to 2<sup>nd</sup> Junior</p>			





**ELECTRICAL CONNECTIONS TO THE TERMINALS AND THEIR FUNCTIONS**

**SAFETY EDGES**

The two inputs, that are fitted to control the safety edges, are separated for the opening and closing phases and are recognized by the Elpro 62 board during the programming phase.

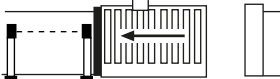
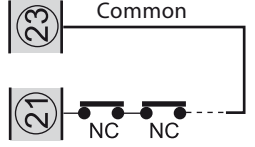
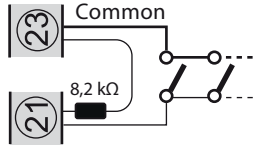
Thanks to a dedicated microcontroller circuit separately fitted on to the board, the actual integrity and correct functioning of the safety edges is constantly controlled. Any possible fault or loss of efficiency is signalled by the L21 and L24 LEDs keeping flashing.

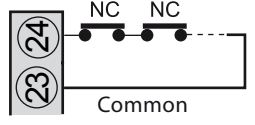
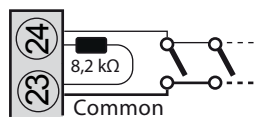
In case an obstacle is detected by the safety edges (or photocells in opening phase), the gate travel is reversed a little bit so that the obstacle can be released.

Accessory	Electrical connections	Dip-switches and LED indication of their functions
<p><b>Input. Photocells and Safety edges in Opening</b></p> 	 <p><i>In series if safety edges are mechanical, N.C.</i></p>  <p><i>In parallel if safety edges are resistive 8,2 kΩ</i></p>	 <p><b>Normally alight:</b> whenever the safety edge is engaged, the LED goes off.</p>
<p><b>Input. Safety edges in Closing</b></p> 	 <p><i>In series if safety edges are mechanical, N.C.</i></p>  <p><i>In parallel if safety edges are resistive 8,2 kΩ</i></p>	 <p><b>Normally alight:</b> whenever the safety edge is engaged, the LED goes off.</p>

**FUNCTIONS: DESCRIPTION OF THE FUNCTIONS OF THE JUNIOR 624 SLIDING OPERATOR**

 **NOTE WELL:** any variation on the DIP-SWITCH setting, to achieve the required functions, will be performed on the subsequent command to open or close, with the exception of DIP-SWITCH No.11 that is learnt and memorized only in the programming phase.

 **ADJUSTMENT OF TORQUE:** The adjustment of the torque by the Trimmer must be sufficient to move the gate. This adjustment also determines the torque on slowing down and impact resistance with an obstacle. Too high torque in relation with the inertia of the gate leads to incorrect installation according to safety standards EN 12445 and EN 12453. Therefore, the installer, once adjusted the force applied to the automated gate, must check the forces as determined by the regulations EN 12445 and EN 12453 documented in the manual "Safety Standards" that the manufacturer provides on request.

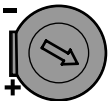
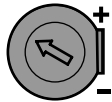
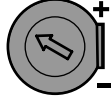
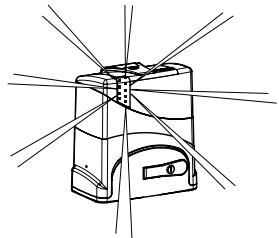
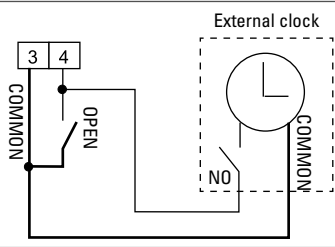
Description	Dip - Switch and LED indication of their functions
<p><b>Automatic/Semiautomatic:</b>  <b>Automatic cycle:</b> upon open command impulse, the gate opens, stops in pause for the time set in the <b>Pause Trimmer</b>, then recloses automatically.  <b>Semiautomatic Cycle:</b> with an open command impulse the gate moves to opening. To close the passage it is necessary to give the close command.</p>	<p><b>DIP-SWITCH 3</b></p> <div style="border: 1px solid black; padding: 5px;"> <p><input checked="" type="checkbox"/> <b>ON:</b> Closes in Automatic Mode</p> <p><input type="checkbox"/> <b>3 OFF:</b> Semiautomatic Mode</p> </div> <p> <b>Pause Trimmer:</b> the pause time is adjusted in the automatic mode from 1s to 120s.</p>
<p><b>Slowdowns:</b>                      During programming it is recommended that the positions of initial slowing in opening and in closing be set. Afterwards, these may be removed or reset by way of the Dip-switch 6.                      The speed of the final run slowdown of the gate is calibrated at the factory, while the torque is proportional to the force exerted by the Junior by the <b>Torque Trimmer</b>.</p>	<p><b>DIP-SWITCH 6</b></p> <div style="border: 1px solid black; padding: 5px;"> <p><input checked="" type="checkbox"/> <b>ON:</b> Slowdowns out of service</p> <p><input type="checkbox"/> <b>6 OFF:</b> Slowdowns in service</p> </div> <p> <b>Torque Trimmer:</b> adjust the torque applied on to the gate.</p>
<p><b>Reverse direction upon contact with obstacle:</b>                      This function enables the inversion of the movement on contact with an obstacle.                      - <b>Opening phase:</b> the function reverses the direction for 10 cm freeing the obstacle                      - <b>Closing phase:</b> the function reverses the direction up to the opening limit switch                      The sensitivity of the function is proportional to the torque exerted by the Junior by way of the Torque Trimmer</p> <p><b>PLEASE NOTE:</b> If the gate detects an obstacle for 5 consecutive times during a complete open - stop - close cycle, the gate will remain open and the lamp will flash with a Blue light, waiting for a command.</p>	<p> <b>Torque Trimmer:</b> adjust the torque applied to the gate.</p> 
<p><b>Closing after passage by the pair of photocells:</b>                      This function enables the automatic closing 3s after the passage through the pair of photocells.</p>	<p><b>DIP-SWITCH 9</b></p> <div style="border: 1px solid black; padding: 5px;"> <p><input checked="" type="checkbox"/> <b>ON:</b> Enables the automatic closing after the passage through the pair of photocells.</p> <p><input type="checkbox"/> <b>9 OFF:</b> No automatic closing</p> </div>
<p><b>DSA: Check photocells before start up</b>                      Device for <b>Safety Autotest</b> = If activated, before opening or closing movements all the security devices are checked for faults. In case any malfunction is detected, the operator is prevented from starting and the LED on the Junior cover keeps flashing with alternated Blue and Orange lights.</p>	<p><b>DIP-SWITCH 10</b></p> <div style="border: 1px solid black; padding: 5px;"> <p><input checked="" type="checkbox"/> <b>ON:</b> DSA control of the photocells. It is absolutely required that photocell projectors be power supplied through terminals 13-14</p> <p><input type="checkbox"/> <b>10 OFF:</b> No DSA control of the photocells</p> </div>
<p><b>Opening by way of external clock:</b>  <b>Connection:</b> connect the NO contact of the clock with terminal 4 OPEN and terminal 3 COMMON in parallel, enabling the automatic closing with the Dipswitch 3= ON  <b>Operation:</b> program the opening time on the clock, at the time set the gate will open and remain open (the flasher goes off) and it will not accept other commands (not even radio) until the time that has been set on the clock runs out. Once that time has expired, after the pause time, the automatic closing will follow.</p>	 <div style="border: 1px solid black; padding: 5px;"> <p><input checked="" type="checkbox"/> <b>ON:</b> Closes in Automatic Mode</p> <p><input type="checkbox"/> <b>3 OFF:</b> Semiautomatic Mode</p> </div>

**PROGRAMMING AND SELF-LEARNING OF THE GATE RUN**

**!** **IMPORTANT:** programming Junior is performed at first installation. Even in absence of mains power, programming is retained in the memory. In case any time position of the limit switch brackets is changed, functions setting by mean of dip-switches or accessories connections are modified, the gate run setting is to be re-programmed accordingly, following the same procedure. With those installations requiring 2 Junior motors (Master and Slave), each Junior must be programmed individually.

**!** **IMPORTANT:** verify the presence of the opening and closing stops, while the opening and closing limit switch brackets must be anchored on the gear rack in the operation positions.

**!** **IMPORTANT:** DURING ALL PROGRAMMING, IT IS NECESSARY TO WAIT FOR AUTOMATIC READING OF THE MAGNETIC LIMIT SWITCH OF THE JUNIOR ON THE OPENING AND CLOSING BRACKETS ANCHORED TO THE GEAR RACK.

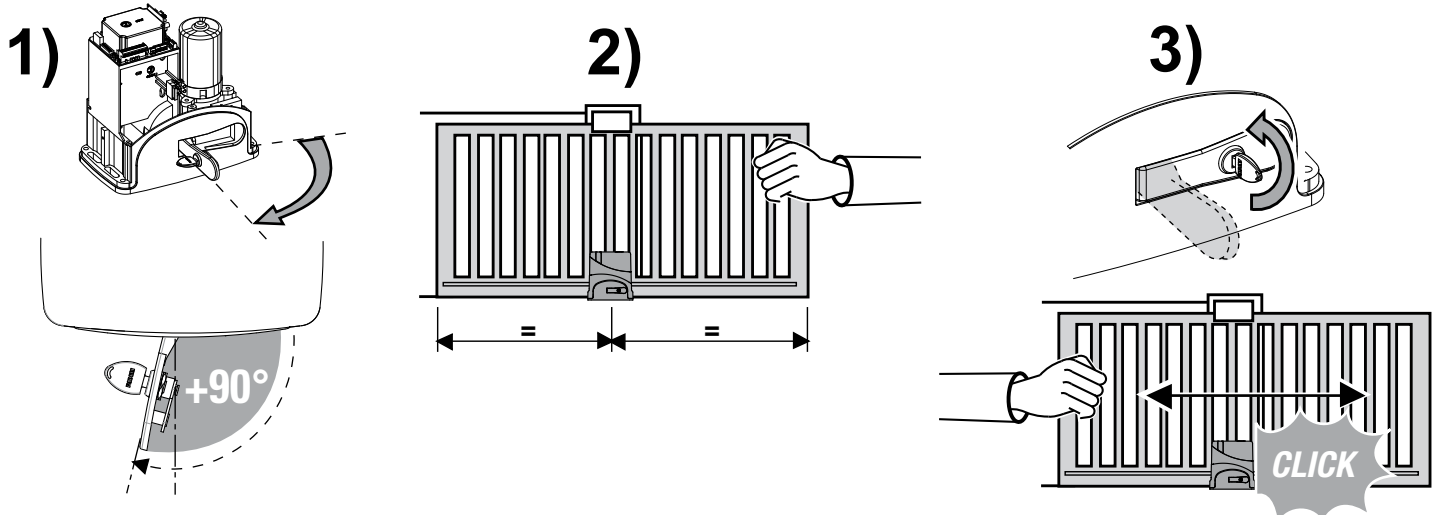

**1<sup>st</sup> Operation:** Unlock the release handle with the coded key and open it until it stops (beyond 90°), thus freeing the gate from the Junior operator. Then push the gate at **about halfway of its run**. Reset locking condition by closing the handle. As a safety measure, when the release handle is disengaged, the electrical power supply to Elpro 62 PCB is disconnected.

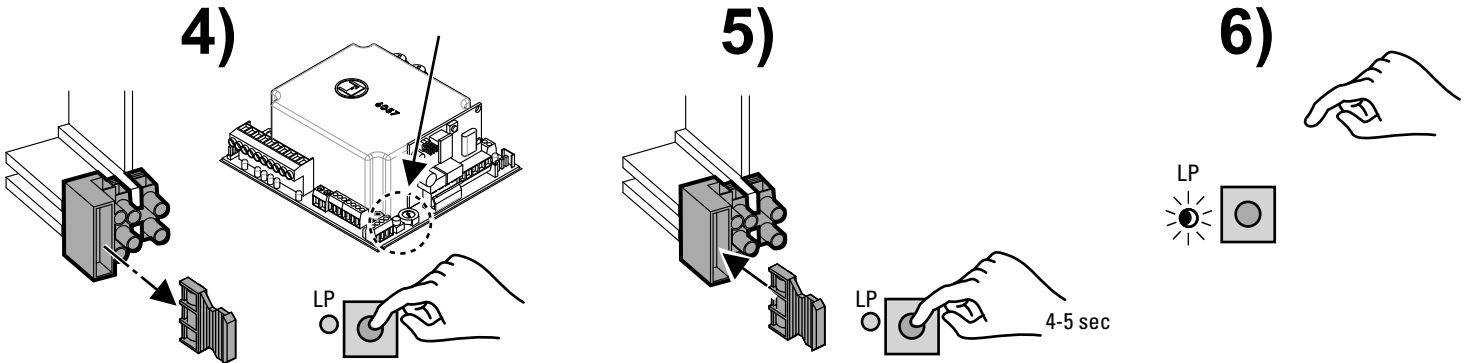

**2<sup>nd</sup> Operation: learning the run pattern and slowdowns.**  
Remove the electrical power supply to the electronic PCB by completely extracting the 230 V line fuse from its seat, located in the front, underneath the Elpro 62 PCB. **Push and hold down the P button** and then afterwards install the line fuse. After 4-5 seconds release the **P button**: the **LP LED** will begin to flash signalling the programming phase.

**7)**  
Push with an impulse: the Junior will begin to move the gate **in opening** direction

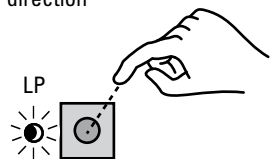

**8)**  
**Beginning of the slowdown:** Push with an impulse: when the start of the slowdown phase is desired **and wait for the limit switch reading**

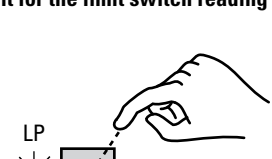

**9)**  
Push with an impulse: the Junior will move the gate **in closing** direction

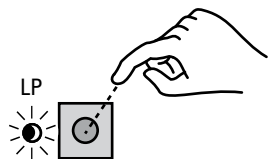

**10)**  
**Beginning of the slowdown:** Push with an impulse: when the start of the slowdown phase is desired **and wait for the limit switch reading**

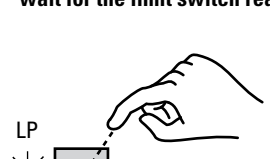

At the end of programming, wait for the LP LED to flash until it finally switches off.



**Pic. 13**

**OPENING OF THE UNLOCKING HANDLE FOR THE MANUAL OPERATION OF THE GATE**

By opening the unlocking handle with the coded key, the **electrical power** supply is always disconnected from the system. For full **unlocking** action and subsequent manual movement of the gate, it is necessary that **the handle be opened until it stops beyond 90°**. Upon closing and subsequent locking of the lock, the **electrical power** supply to the PCB is reset.

**IMPORTANT: Once the electrical power supply has been disconnected using the unlocking key, upon return of the mains electrical power, the first movement of the Junior operator is always towards closing at a normal operational speed with no programmed slowdowns. All of the programmed functions are resumed with the next complete cycle (opening-stop-closing).**

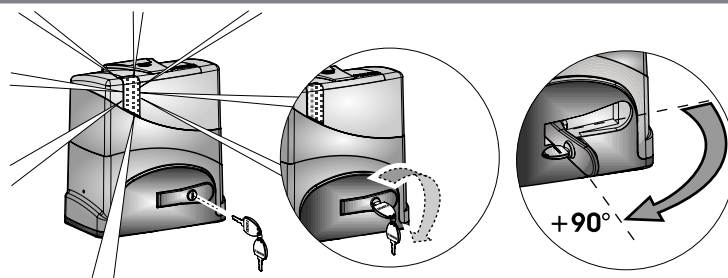

1) Insert the Customised key

2) Turn the key: power supply disconnects (blue light off)

3) Open the handle: fully open the handle to its stop

Pic. 14

**ELECTRICAL POWERING BY WAY OF THE BACK-UP BATTERY**

If there is a mains electrical power failure to the system it is possible to power Elpro 62 by way of commercial type back-up batteries, with **two 12 V / 2.2 Ah / 2.6 Ah** batteries, to be lodged in the front, above the cable inlet (autonomy of about 15 complete cycles per hour). The connection must be made with 4.2 faston connector, in series to the input terminals on the PCB, as in the picture.

It is important to respect the polarity “+” and “-”.

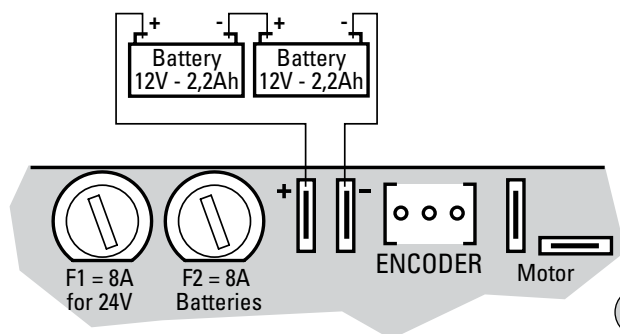

Pic. 15

With mains electrical power connected and functioning, the back-up batteries, if connected to the terminals on the Elpro 62, are automatically recharged (with board Elpro 62 powered at 230V)

Battery backup:  
No. 2 pieces of 12V  
2.2Ah/2.6Ah

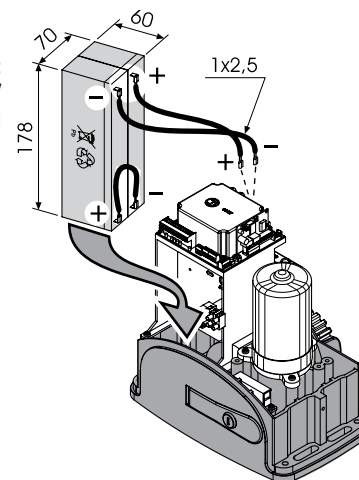

Pic. 16

For proper housing, it is necessary that the spade connectors of the two batteries are placed in front of the installer, with the polarity “+” of the first battery to be inserted at the top.

**MALFUNCTION CAUSES AND NECESSARY OPERATIONS**

The “LED” device on the protective casing is a fixed light **BLUE** when the automatism is working properly. It flashes or becomes **ORANGE** in the presence of any electrical system faults.

Faults	Cause	Operations
<b>The gate will not move</b>	<ul style="list-style-type: none"> <li>- No programming performed</li> <li>- One or more NC contacts open</li> <li>- Burnt fuses</li> <li>- Torque too low</li> <li>- Photocells not aligned or disturbed</li> </ul>	<ul style="list-style-type: none"> <li>- Perform programming (page 30)</li> <li>- Check all NC contacts (green LEDs must all be on)</li> <li>- Check conditions of all fuses</li> <li>- Enable the Torque Trimmer to increase it</li> <li>- Align photocells and verify conditions</li> </ul>
<b>LED lamp on casing off</b>	<ul style="list-style-type: none"> <li>- No 230 V power</li> <li>- 5 A line fuse burnt</li> <li>- 630 mA fuse for 24 V burnt</li> <li>- Unlocking handle not locked</li> </ul>	<ul style="list-style-type: none"> <li>- Check the line and all fuses</li> <li>- The gate might have run into either gate stops. Adjust the limit switch brackets (see page 23)</li> <li>- Close and remove the key from the lock</li> </ul>
<b>LED lamp on casing flashing BLUE</b>	<ul style="list-style-type: none"> <li>- An obstacle or a possible friction have been detected during the gate movement for 5 consecutive times</li> </ul>	<ul style="list-style-type: none"> <li>- Remove obstacles and give an opening/closing command</li> <li>- Remove possible causes of friction on the sliding gate track/guides</li> <li>- The gate might have run into either gate stops. Adjust the limit switch brackets (see page 23)</li> </ul>
<b>LED lamp on casing alternatively flashing BLUE-ORANGE</b>	<ul style="list-style-type: none"> <li>- Photocell malfunction on DSA control carried out before movement</li> </ul>	<ul style="list-style-type: none"> <li>- Realign the photocells</li> <li>- Disconnect power to photocells for a few seconds</li> <li>- Power supply for DSA photocells is to be connected to the terminals 13-14</li> </ul>
<b>The gate starts moving, then it stops or reverses</b>	<ul style="list-style-type: none"> <li>- Detects the continuous presence of an obstacle or possible friction during movement</li> <li>- Photocells not aligned</li> </ul>	<ul style="list-style-type: none"> <li>- Remove obstacles and give an opening/closing command</li> <li>- Enable the Torque Trimmer to increase it</li> <li>- Realign the photocells</li> </ul>



**MAINTENANCE RECORD**  
hand over to the end user of the installation



Installation address:	Maintainer:	Date:
-----------------------	-------------	-------

Installation type: <b>Sliding gate</b> <input checked="" type="checkbox"/> <b>Folding door</b> <input type="checkbox"/> <b>Swinging gate</b> <input type="checkbox"/> <b>Road barrier</b> <input type="checkbox"/> <b>Over-head door</b> <input type="checkbox"/> <b>Bollard</b> <input type="checkbox"/> <b>Lateral folding door</b> <input type="checkbox"/> ..... <input type="checkbox"/>	Operator model:	Quantity of models installed:	Dimensions per gate leaf:
	Weight per gate leaf:	Installation date:	

**NOTE WELL:** this document must record any ordinary and extraordinary services including installation, maintenance, repairs and replacements to be made only by using Fadini original spare parts. This document, for the data included in it, must be made available to authorized inspectors/officers, and a copy of it must be handed over the end user/s.

The installer/maintainer are liable for the functionalities and safety features of the installation only if maintenance is carried on by qualified technical people appointed by themselves and agreed upon with the end user/s.

N°	Service date	Service description	Technical maintainer	End user/s
1				
2				
3				
4				
5				
6				

\_\_\_\_\_  
Stamp and signature  
installation technician/maintainer

\_\_\_\_\_  
Signed for acceptance  
end user  
buyer

hand over to the end user of the installation



**DATI TECNICI****Dati tecnici**

Tensione di alimentazione	230 V - 50 Hz
Tensione motore	24 Vdc
Potenza assorbita max.	220 W
Corrente assorbita max.	6,3 A
Forza di spinta massima	400 N
Peso massimo cancello	400 kg
Numero di giri motore	3.000 rpm
Velocità	12 m/1'
Rapporto	1:61
Grado di protezione	IP 54
Tipo di olio	Oil Fadini - cod. 706L
Temperatura di lavoro	-20°C +50°C
Peso	11 kg
Frequenza utilizzo	Intensivo
Ciclo di servizio: 30 s apertura/chiusura - 30 s pausa	
Tempo ciclo completo: 120 s = massimo 30 cicli/ora	

La Ditta costruttrice si riserva di apportare modifiche al presente libretto senza preavviso, inoltre non si assume nessuna responsabilità per eventuali errori o danni a cose e persone.

**TECHNICAL SPECIFICATIONS****Technical specifications**

Electrical power supply voltage	230 V - 50 Hz
Motor power supply	24 Vdc
Power absorbed max	220 W
Current Absorbed max	6,3 A
Maximum thrust force	400 N
Weight of the gate	400 kg
Motor revolutions	3.000 rpm
Speed	12 m/1'
Ratio	1:61
Protection Grade	IP 54
Oil type	Oil Fadini - Item 706L
Operational temperature	-20°C +50°C
Junior weight	11 kg
Frequency of use	Intensive
Duty cycle: 30 s opening/closing - 30 s pause	
Complete cycle time: 120 s = maximum 30cycles/hour	

The manufacturing firm reserves the right to modify this manual without notice; in addition it assumes no responsibility for possible errors or damages to properties or persons.

**DONNEES TECHNIQUES****Données techniques**

Tension d'alimentation	230 V - 50 Hz
Tension moteur	24 Vdc
Puissance absorbée max.	220 W
Courant absorbé max.	6,3 A
Force de poussée maximale	400 N
Poids max du portail	400 kg
Nombre de tours du moteur	3.000 rpm
Vitesse	12 m/1'
Rapport	1:61
Degré de protection	IP 54
Type d'huile	Oil Fadini - art. 706L
Température de service	-20°C +50°C
Poids	11 kg
Fréquence d'utilisation	Intensive
Cycle de service: 30 s ouverture/fermeture - 30 s pause	
Temps de cycle complet: 120 s = maximum 30 cycles/heure	

Le fabricant se réserve le droit de modifier ce manuel d'instructions sans préavis et décline toute responsabilité en cas d'erreurs et/ou dommages matériels ou personnels.

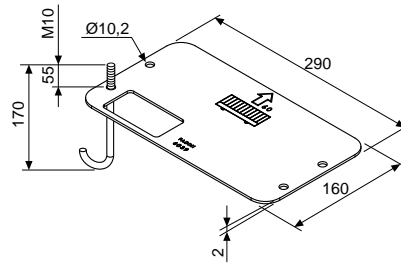
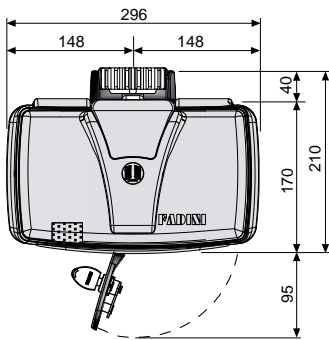
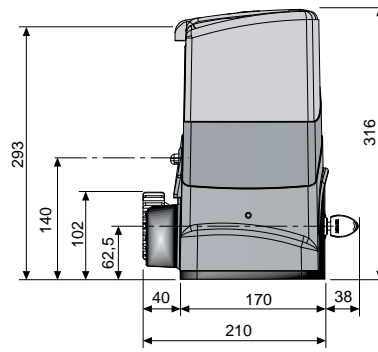
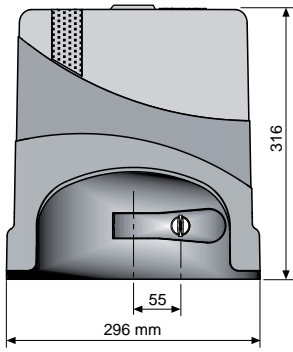

Piastra di fondazione  
Base plate  
Plaque de fondation

Timbro dell'Installatore  
Installer's Stamp  
Cachet de l'installateur



**meccanica**  
**FADINI**

Via Mantova, 177/A - 37053 Cerea (VR) Italy  
Ph +39 0442 330422 Fax +39 0442 331054  
info@fadini.net www.fadini.net